

SharpEye™

CCTV Model Flame Detector

Model 20/20CTIN-CTIP

User and Maintenance Manual

TM 788100, Rev. A January 2005



ATEX Approved

Ex II 2G
EExd IIB + H₂ T5
EExde IIB + H₂ T5

UL Approved

Class I, Groups C and D

Gost R Approved

1ExdIIBT5/H₂

GasTech Australia
106 Westpoint Centre
396 Scarborough Beach Road
Telephone 1800 999 902
Facsimile 1800 999 903
<http://www.gastech.com.au>

GASTECH
AUSTRALIA

The SharpEye Optical Flame Detector described in this document is the property of Spectrex, Inc.

No part of the hardware, software or documentation may be reproduced, transmitted, transcribed, stored in a retrieval system, or translated into any language or computer language, in any form or by any means, without prior written permission of Spectrex, Inc.

While great efforts have been made to assure the accuracy and clarity of this document, Spectrex, Inc. assumes no liability resulting from any omissions in this document, or from misuse of the information obtained herein. The information in this document has been carefully checked and is believed to be entirely reliable with all of the necessary information included. Spectrex Inc. reserves the right to make changes to any products described herein to improve reliability, function, or design, and reserves the right to revise this document and make changes from time to time in content hereof with no obligation to notify any persons of revisions or changes. Spectrex, Inc. does not assume any liability arising out of the application or any use of any product or circuit described herein; neither does it convey license under its patent rights or the rights of others.

Warning:

This manual should be carefully read by all individuals who have or will have responsibility for using, maintaining or servicing the product.

The Detector is not field-repairable due to the meticulous alignment and calibration of the sensors and the respective circuits. Do not attempt to modify or repair the internal circuits or change their settings, as this will impair the system's performance and void the Spectrex, Inc. Product warranty.

TABLE OF CONTENTS

1. Scope	1
1.1 PRODUCT OVERVIEW.....	1
1.2 DOCUMENT OVERVIEW	2
2. Technical Description	3
2.1 PRINCIPLES OF OPERATION	3
2.1.1 Hydrocarbon fire detection.....	3
2.1.2 Identifying the CO ₂ peak.....	3
2.1.3 The limitations of IR-IR flame detectors	3
2.1.4 The advantages of IR3 technology.....	3
2.1.5 Video Picture.....	5
3. Performance	6
3.1 DETECTION SENSITIVITY	6
3.2 FALSE ALARMS PREVENTION.....	9
4. Operation	10
4.1 VISUAL INDICATIONS.....	10
4.2 OUTPUT SIGNALS	11
4.2.1 Optional latching.....	12
4.2.2 Built-In-Test (BIT).....	12
4.2.3 CCTV Output.....	12
4.3 MODE SELECTION	13
4.3.1 Function Setup.....	14
4.3.2 Sensitivity Ranges.....	14
4.3.3 Alarm Delay.....	15
4.3.4 Addresses Setup	15
4.4 BUILT IN TEST.....	16
5. Technical Specifications	18
5.1 ELECTRICAL SPECIFICATIONS	18
5.2 MECHANICAL SPECIFICATIONS.....	21
5.3 ENVIRONMENTAL SPECIFICATIONS	22
6. Installation Instructions.....	23
6.1 SCOPE	23
6.2 GENERAL CONSIDERATIONS	23
6.3 PREPARATIONS FOR INSTALLATION	24
6.4 CONDUIT INSTALLATION	24
6.5 DETECTOR MOUNTING.....	25
6.5.1 Swivel Mount Kit:.....	25
6.5.2 Swivel installation (Figs. No. 8 and 9):.....	25
6.6 WIRING (REFER TO FIG. 11).....	28
6.7 TERMINAL WIRING (SEE FIG. NO.10 AND NO.11.).....	29
6.8 OPERATION MODE.....	32
7. Operating Instructions.....	33
7.1 SCOPE	33
7.2 POWER-UP.....	33
7.3 RESET.....	33

7.4 FUNCTIONAL TESTING	33
7.4.1 Manual BIT Test	34
7.4.2 Testing with fire simulator	34
7.5 SAFETY PRECAUTIONS.....	35
8. Maintenance Instructions	36
8.1 SCOPE	36
8.2 MAINTENANCE INSTRUMENTATION AND PERSONNEL.....	36
8.3 PREVENTIVE MAINTENANCE PROCEDURES.....	36
8.4 PERIODIC MAINTENANCE PROCEDURES.....	36
8.4.1 Power-Up Procedure	36
8.4.2 Functional Test Procedure.....	36
8.5 MAINTENANCE RECORDS.....	37
8.6 TROUBLESHOOTING.....	37
8.6.1 Fault Indication	37
8.6.2 False Alarm or Warning Indication	37
Appendix A - Wire Selection Tables.....	39
Appendix B – Typical Wiring Configurations	41
Appendix C – RS-485 Communication Network.....	45
Appendix D - Mounting the “EExde approved” version	47
Appendix E - Long Range IR3 Fire Simulator	51

LIST OF FIGURES

Figure 1: CCTV Model Flame Detector	4
Figure 2: Flame Detector Assembly - Outline Drawing	5
Figure 3: Horizontal and Vertical Fields of View.....	8
Figure 4: Indication LEDs.....	10
Figure 5: CCTV Screen Setup.....	13
Figure 6: Electrical Interface	18
Figure 7: Flame Detector Assembly - Schematic Section	20
Figure 8: IR3 Detector and Swivel Mount Assembly.....	26
Figure 9: Swivel Mount Assembly - Outline Drawing.....	27
Figure 10: Terminal Board.....	30
Figure 11: IR3 Flame Detector with cover removed.....	31
Figure 12: Flame Detector Wiring Diagram.....	41
Figure 13: Typical wiring diagram for 4 wire controllers	42
Figure 14: 4-20mA wiring	43
Figure 15: RS-485 networking.....	45
Figure 16: Flame Detector Assembly - Wiring Diagram	49
Figure 17: Flame Detector Assembly - Wiring Diagram (“de version”)	50
Figure 18: Fire Simulator.....	51
Figure 19: IR3 Detector Target Point.....	52

LIST OF TABLES

Table 1: Alarm Response Time Versus Range	6
Table 2: Response Sensitivity Ranges.....	7
Table 3: Cone of Vision	8
Table 4: Immunity To False Alarm Sources	9
Table 5: Welding Immunity Distance	9
Table 6: Output Signals Versus Detector State.....	11
Table 7: Built-in Test	12
Table 8: Functions setting for model 20/20 CTIN and model CTIP.....	14
Table 9: Sensitivity range	14
Table 10: Time delay.....	15
Table 11: Contact Ratings	19
Table 12: Mounting according to US Version.....	25
Table 13: Mounting according to EU Version	25
Table 14: Maximum DC resistance at 68 °F for copper wire.....	39
Table 15: Wiring length in feet (meter).....	39

1. Scope

1.1 Product Overview

The SharpEye CCTV Model Flame Detector (20/20CTIN and 20/20CTIP) is a self-contained, triple-spectrum, optical flame detector that incorporates a video color camera. The detector's IR sensors and spectral band pass filters have been selected to ensure the greatest degree of spectral matching to the radiant energy emissions of fire and the lowest degree of matching to non-fire stimuli.

The color video camera enables the user to investigate the monitored area, to identify the fire's source and location, and help select the best response to the situation (activation of fire suppression means).

Configuration can be made to issue a live color video picture signal at all times, on request or only when a fire is detected. Therefore, the detector is also useful for standard CCTV purposes.

The front side of the detector is sealed to keep the electronic and sensor chamber dry for longer life. The programmable functions are available through a RS 485 port used with a standard PC or by a Pocket PC and software supplied by Spectrex.

The video signal output of the CCTV Model Flame Detector can be either NTSC or PAL.

Refer to Manual TM 784050 for instructions to use the HOST software and to change the required Functions.

1.2 Document Overview

This manual describes the detector and its features and provides instructions on the installation, operation and maintenance.

This manual is divided into separate chapters as follows:

- Chapter 1. **Scope** - a general introduction and overview of the product and the Manual, with a brief description of its content.
- Chapter 2. **Technical Description** - the detector's theory of operation.
- Chapter 3. **Performance** - the detector features and capabilities.
- Chapter 4. **Operation** - the detector's operation modes, user interface and indications.
- Chapter 5. **Technical Specifications** - the Detector's electrical, mechanical and environmental specifications.
- Chapter 6. **Installation Instructions**, including wiring and mode setting.
- Chapter 7. **Operating Instructions** and power-up procedures.
- Chapter 8. **Maintenance Instructions** and support procedures.
- Appendix A. **Wiring Selection Tables** for electrical wire selection according to installation configuration.
- Appendix B. **Typical Wiring Configurations** - wiring diagrams for installation.
- Appendix C. **RS-485 Communication Network**
- Appendix D. **Mounting the "EExde approved" version**
- Appendix E. **Long Range IR3 Fire Simulator**

2. Technical Description

- **Detection Range:** up to 200 ft (60m) for a 1ft x 1ft (0.3m x 0.3m) fire.
- **Live color video image**
- **Ultra High Immunity to False Alarms** (see section. 3.3).
- **Advanced Digital Processing of the Dynamic Characteristics of Fire:**
Flickering, Threshold correlation and Ratio.
- **Three Separate IR Channels:** Between 3-5 microns.
- **Field Programmable Sensitivity:** four ranges.
- **Two Response Levels:** Warning & Detection.
- **Solar Blind**
- **Microprocessor Based:** Digital signal processing.
- **Built In Test:** Manual and Automatic (see section. 4.2.2).
- **Electrical Interface:**
 - Dry contact RELAYS.
 - Communication network RS-485.
 - 4-20mA output.
- **Certification:** Approved by ATEX, UL & GOST R.

2.1 Principles Of Operation

2.1.1 Hydrocarbon fire detection

The triple IR flame detector detects all conceivable types of hydrocarbon fires, i.e. any fire, which emits CO₂.

2.1.2 Identifying the CO₂ peak

The hydrocarbon fire is characterized by a typical radiation emission. The CO₂ peak emits intense radiation in the spectral band between 4.2 μ - 4.5 μ and weaker radiation intensity outside this spectral band.

2.1.3 The limitations of IR-IR flame detectors

CO₂ in the atmosphere attenuates the radiation in this spectral band. (Absorption and emission of radiation always occur in the same band.) As a result, the greater the distance between the detector and the fire, the weaker the intensity of the radiation reaching the detector (the CO₂ attenuation increases). This phenomenon explains the limitations of the existing IR-IR flame detectors in the market:

- Detection distance is restricted to 33ft (10m) only.
- Their immunity to false alarm sources is limited.

2.1.4 The advantages of IR3 technology

To overcome these limitations, Spectrex Inc. revised an innovative concept of utilizing an additional detection channel. Three channels collect more data from the environment, permitting more accurate analysis and better performance.

After careful investigation, three channels were selected which, when operating jointly, provide optimal fire detection characteristics:

Channel 1: 4.2 μ - 4.6 μ

Fire - the CO₂ peak

Channel 2: 4.0 μ - 4.2 μ

Eliminates false alarms from high temperature sources.

Channel 3: 4.8 μ - 5.2 μ

Eliminates false alarms from flickering of background radiation.

Most IR sources, which create misleading IR alarm stimuli, including the sun, incandescent and halogen lamps, electric arc discharges, electrical heaters, etc., do not possess this unique spectral signature of fire. The IR sensors of the detector respond only to flickering of radiation signals. The signals are compared to a predetermined threshold. Processing of the results from the three IR channels is performed by the board microprocessor. The result is a much greater detection distance and a highly increased ability to distinguish between fire and false alarms. This sophisticated technology surpasses all other existing flame detection techniques on the market today.

This unique flame analysis capability (patent pending) has been incorporated into the Triple-IR fire detector manufactured by Spectrex, Inc. The result is a unique flame detector, which does not produce false alarms and provides at the same time detection over greatly increased distances.

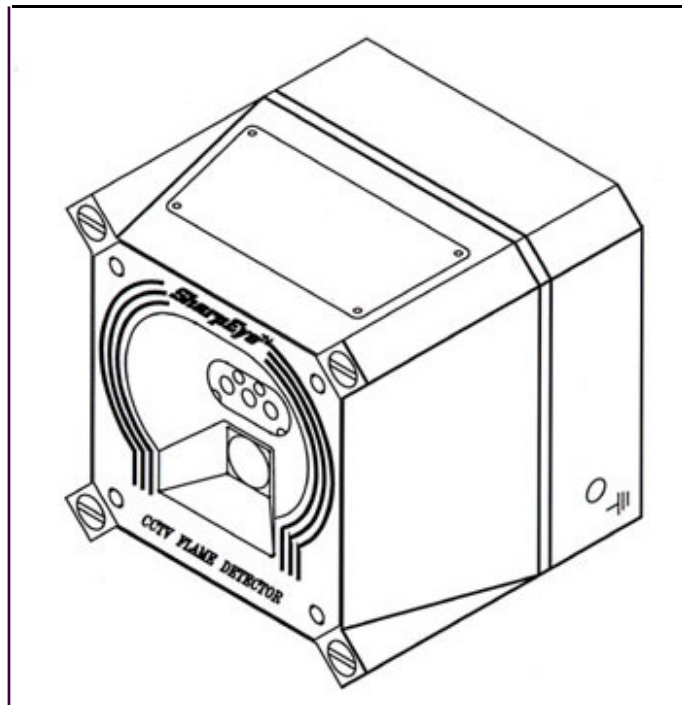

Figure 1: CCTV Model Flame Detector

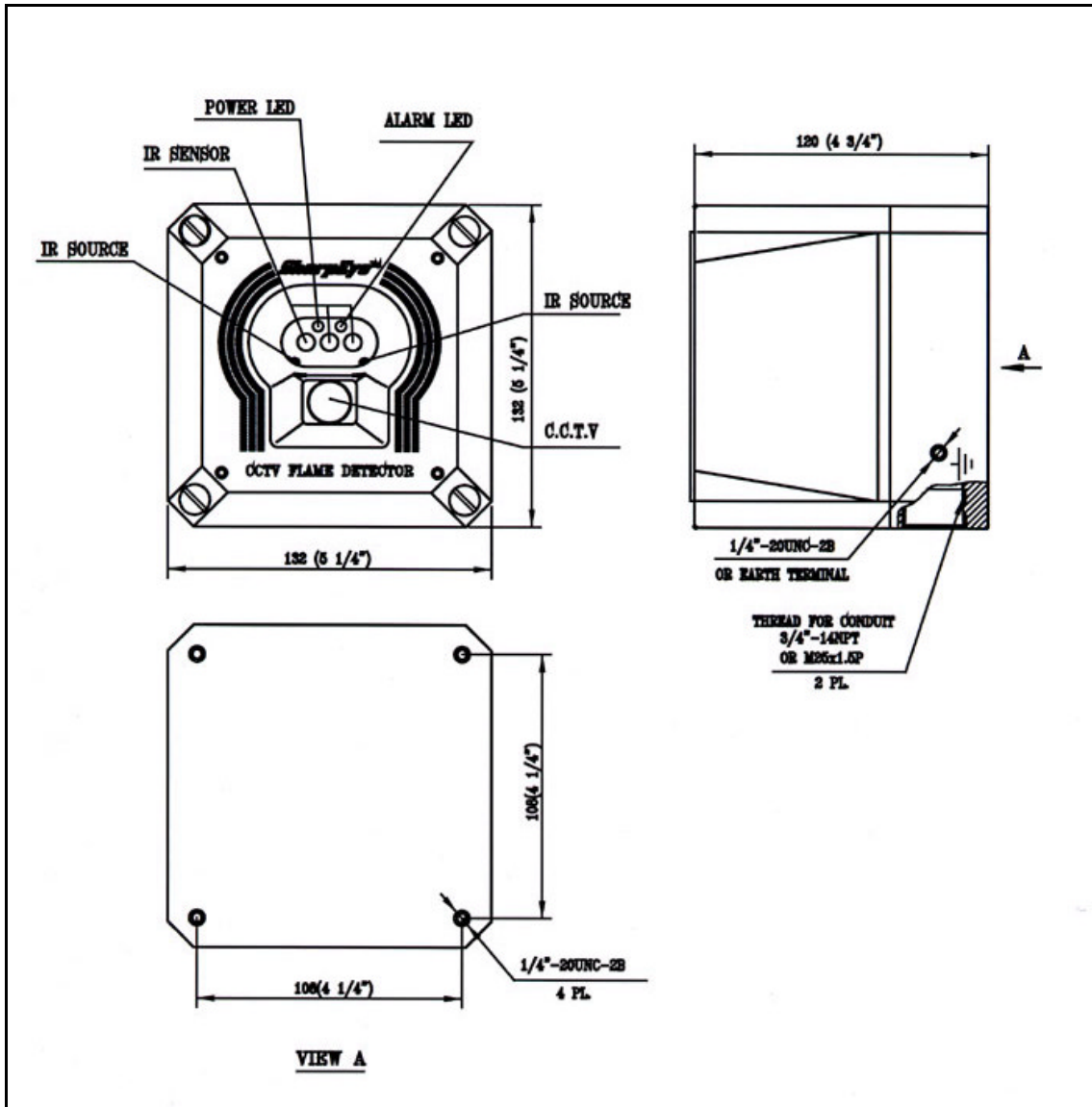

Figure 2: Flame Detector Assembly - Outline Drawing

2.1.5 Video Picture

The color video camera enables the user to investigate the monitored area, to identify the fire source and location, to help select the best response to the situation (activation of fire suppression means). Configuration can be made to issue a live color video picture signal at all times, on request, or only when a fire is detected; therefore, the detector is also useful for standard CCTV purposes.

3. Performance

3.1 Detection Sensitivity

A. Flame

Detection sensitivity is the maximum distance at which the detector will reliably detect a specific size of fire & typical type of fuel (standard fire).

Standard Fire:

A 1ft x 1ft (0.3m x 0.3m) Gasoline pan fire with max. wind speed of 6.5 ft/sec (2 m/sec).

Sensitivity Ranges:

The detector has four user selectable sensitivity ranges. For each range there are two response levels.

1. WARNING (Pre-alarm)
2. ALARM

The detection distance, for the WARNING level, is approximately 10% longer than the ALARM distance. Alarm response times for a “standard fire” at a specified range are shown hereunder.

Table 1: Alarm Response Time Versus Range

Sensitivity	1	2	3	4
Range – ft (m)	50 (15)	100 (30)	150 (45)	200 (60)
Response Time (sec)	3	5	8	10

For some typical ambient conditions the Zeta parameter as defined in NFPA 72 for the detector is 0.005 (1/meter).

Note:

Zeta parameters may vary significantly with changes in temp, air pressure, humidity, visibility conditions, etc.

Other fuels

The detector will react to other types of fires as follows:

Pan Fire Size: 1ft x 1ft (0.3m x 0.3m)

Maximum Wind Speed: 6.5 ft/sec (2 m/sec)

Maximum Response Time: 10 sec

Table 2: Response Sensitivity Ranges

Type Of Fuel	% Of Max. Distance at Each Sensitivity Range
Gasoline	100%
N-Heptane	100%
Alcohol 95%	75%
JP4	75%
Kerosene	75%
Diesel Fuel	70%
Methane*	30%
Propane*	30%

* 0.5m plume fire

B. CCTV

The CCTV picture enables the user to identify a 1x1 foot gasoline flame from a distance of 100 feet (30 meters) offering a “live video” image of the monitored area.

3.2 Cone Of Vision

Table 3: Cone of Vision

	Flame Detector	CCTV
Horizontal	90°	90°
Vertical	90°	65°

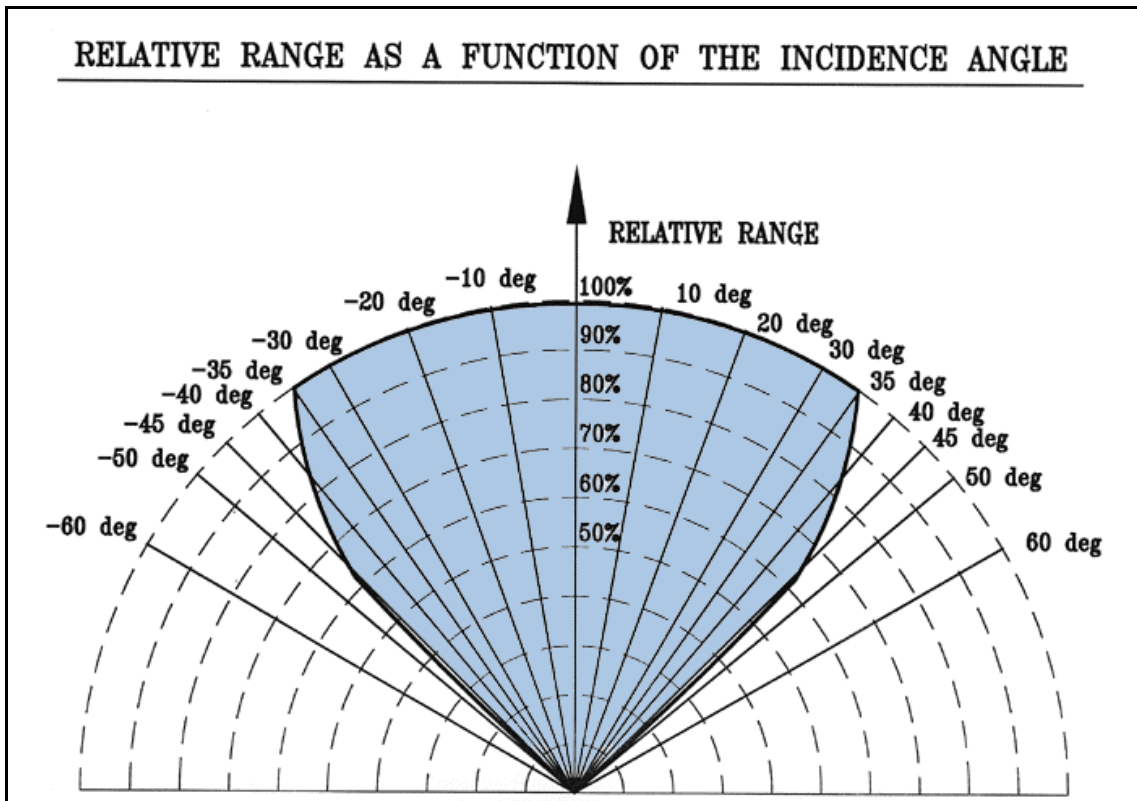

Figure 3: Horizontal and Vertical Fields of View

3.2 False Alarms Prevention

The detector will not provide an alarm or a warning signal as a reaction to the radiation sources specified below.

Notes:

IAD = Immune at Any Distance.

All sources are chopped from 0 to 20Hz.

Table 4: Immunity To False Alarm Sources

Radiation Source	Immunity Distance ft(m)
Sunlight	IAD
Indirect or reflected sunlight	IAD
Vehicle headlights (low beam) conforming to MS53023-1	IAD
Vehicle IR lights (low beam) conforming to MS 53024-1	IAD
Incandescent frosted glass light, 100 W	IAD
Incandescent clear glass light, rough service, 100 W	IAD
Fluorescent light with white enamel reflector, standard office or shop, 40 W (or two 20 W)	IAD
Electric arc [12mm (15/32 in) gap at 4000 V alternating current, 60 Hz]	IAD
Arc welding [4 mm (5/32 in) rod; 240 A]	See Table 4
Ambient light extremes (darkness to bright light with snow, water, rain, desert glare and fog)	IAD
Bright colored clothing, including red and safety orange.	IAD
Electronic flash (180 watt-seconds minimum output)	IAD
Movie light, 625 W quartz DWY lamp (Sylvania S.G.-55 or equivalent)	6.5 (2)
Red dome light conforming to MS51073-1	IAD
Blue-green dome light conforming to M251073-1	IAD
Flashlight (MX 991/U)	IAD
Radiation heater, 1500 W	IAD
Radiation heater, 1000 W with fan	IAD
Quartz lamp (1000 W)	10 (3)
Mercury vapor lamp	IAD
Grinding metal	IAD
Lit cigar	1 (0.3)
Lit cigarette	1 (0.3)
Match, wood, stick including flare up	10 (3)

Table 5: Welding Immunity Distance

SW setting	Detection Range	Immunity Distance
1	50 ft (15m)	>13 ft (4m)
2	100 ft (30m)	>20 ft (6m)
3	150 ft (45m)	>30 ft (9m)
4	200 ft (60m)	>40 ft (12m)

4. Operation

4.1 Visual Indications

Two LED-indications are located in the detector front window:

- i. Power LED (Yellow)
 - Normal - LED ON
 - BIT failure - LED flashes (4 Hz)
- ii. Alarm LED (Red)
 - Normal - LED OFF
 - Warning - LED flashes (2 Hz)
 - ALARM - LED ON

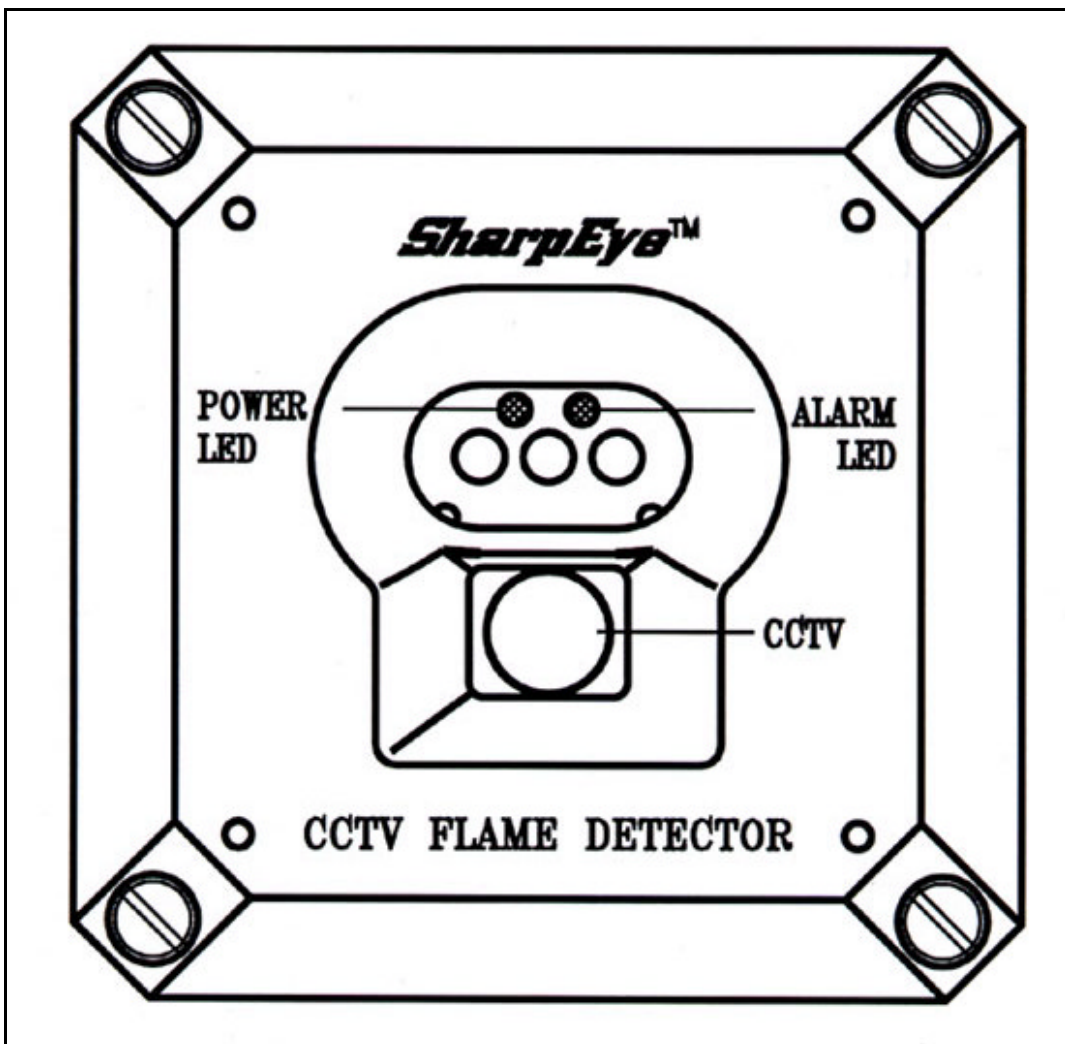

Figure 4: Indication LEDs

4.2 Output Signals

The detector controls the following outputs:

- Alarm relay
- Accessory relay
- Fault relay
- 4-20mA current output
- RS-485 communication

The detector can be in one of the following states.

Normal:	The detector is functioning normally.
BIT:	The detector performs a Built-In-Test.
Warning:	Fire detected - changed to warning – pre-alarm state.
Alarm:	Fire detected - changed to fire alarm state.
Latched Alarm (Optional)	The alarm outputs are latched due to the detection of a fire that has already been extinguished.
Fault:	A fault is detected during a BIT sequence or the power supply is too low. In each state the detector will activate different outputs as specified in table 6.

Table 6: Output Signals Versus Detector State

Detector State	Power Led	Alarm Led	Alarm Relay	Accessory Relay	Fault Relay	4-20mA Output
Normal	On	Off	Off	Off	On	5mA
Warning	On	Flash 2Hz	Off	On	On	10mA
Alarm (4)	On	On	On	On	On	15mA
Latch (2)	On	Off	On	Off	On	5mA
Fault (3)	Flash 4Hz	Off	Off	Off	Off	0mA

Note:

1. The video output can be activated continuously or only when a fire is detected, according to programmable function. See Table 8
2. The Alarm state can be latched, according to programmable function
3. The detector will be in its BIT FAULT state until it has passed a successful BIT.
4. The alarm outputs will be activated as long as the alarm conditions are present and will stop approximately 5 seconds after the fire is no longer detected.

4.2.1 Optional latching

The detector includes an optional latched alarm output capability, which operates according to the programmable function. Upon the detection of a fire, the detection signal is latched until manually reset (disconnecting the power supply or performing a manual BIT).

4.2.2 Built-In-Test (BIT)

Successful **Manual BIT** will activate the following outputs according to programmable function.

Table 7: Built-in Test

ALARM BIT AT YES	The ALARM relay will be activated for 3 seconds. The 4-20mA output will provide 15 mA for 3 seconds.
Accessory BIT AT YES	The camera will be activated for 3 seconds. The 4-20mA will provide 10 mA for 3 seconds.

4.2.3 CCTV Output

The video output is a standard port with two options:

- a. Detector model No. 20/20 CTIN is a NTSC version
- b. Detector model No. 20/20 CTIP is a PAL version

The video output can be activated continuously or only when a fire is detected, according to programmable function. See Table 8

4.3 Mode Selection

The setup screen allows viewing and programming of the detector functions.

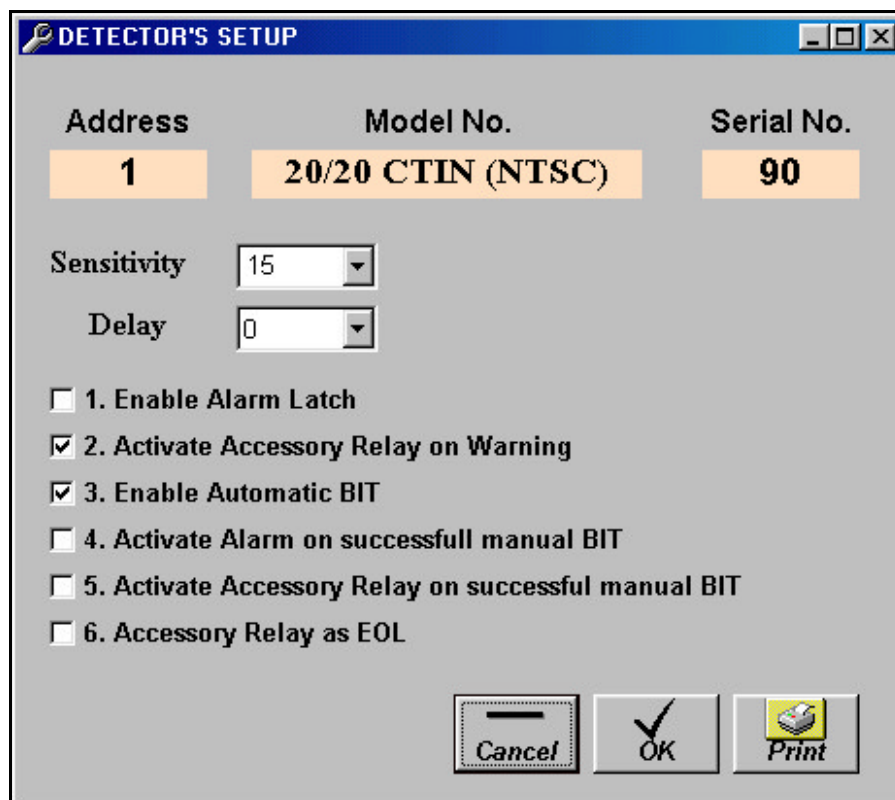

The screenshot shows a window titled "DETECTOR'S SETUP" with the following fields and options:

Address	Model No.	Serial No.
1	20/20 CTIN (NTSC)	90

Sensitivity: 15
Delay: 0

- 1. Enable Alarm Latch
- 2. Activate Accessory Relay on Warning
- 3. Enable Automatic BIT
- 4. Activate Alarm on successful manual BIT
- 5. Activate Accessory Relay on successful manual BIT
- 6. Accessory Relay as EOL

Buttons: Cancel, OK, Print

Figure 5: CCTV Screen Setup

4.3.1 Function Setup

The user can select the desired mode of operation by means of host software connected etc.

Table 8: Functions setting for model 20/20 CTIN and model CTIP

#	Name	YES	NO
1	ALARM LATCH	Alarm latching enable	Alarm latching disable (default)
2	ACCESSORY RELAY (camera operation)	Camera activated at warning level	Camera activated at detection level (together with alarm relay) (default)
3	AUTOMATIC BIT	Automatic & manual bit (default)	Manual bit only
4	ALARM BIT	Successful manual bit activates the Alarm Relay for approximately 3 seconds The 4-20mA will initiate 15mA (default)	Successful manual bit does not activate the Alarm Relay
5	VIDEO OUTPUT	Successful manual bit activates the the camera for approximately 3 seconds The 4-20mA will initiate 10mA (default)	Successful manual bit does not activates the camera
6	EOL	Camera always active (default)	Camera operates in accordance with other settings

4.3.2 Sensitivity Ranges

The detector offers four (4) sensitivity settings. The settings refer to the gasoline 1x1foot fire, from low sensitivity of 50 ft (15m) to 200 ft (60m). For other types of fuel sensitivity, refer to table 2.

Table 9: Sensitivity range

	IR3 Flame Detector Sensitivity
15	50 ft (15 m)
30	100 ft (30 m) (defulat)
45	150 ft (45 m)
60	200 ft (60 m)

4.3.3 Alarm Delay

The detector is equipped with an Alarm Delay option, which provides programmable time delays of 0 to 30 seconds with eight (8) fixed settings at: 0, anti-flare, 3, 5, 10, 15, 20, and 30 seconds.

When an Alarm (Detection) level condition is encountered, the detector delays the execution of the Alarm output's relay by the specified period of time. The detector will then evaluate the condition for 3 seconds. If the Alarm level is still present, the Alarm outputs will be activated. If this condition no longer exists, the detector will return to its standby state. The Alarm delay option will affect the output relay and the 4-20mA. The LEDS will indicate warning level during the delay time only if the fire condition exists.

Anti Flare

Anti Flare mode is selected to prevent false alarm in locations where fast flares may be present. The Time delay for fire alarm in this mode is from 2.5 to 15 seconds (mostly less than 10 seconds).

Table 10: Time delay

Delay (sec.)
0
A* -- anti-flare
3
5
10
15
20
30

* Default

4.3.4 Addresses Setup

Refer to TM 784050 for instructions for defining the addresses of the detectors. The detector provides up to 247 addresses that can be used with RS-485 communication link.

4.4 Built In Test

A. General

The detectors' Built In Test (BIT) checks the following:

- Electronics circuitry
- Sensors
- Window cleanliness

The detector can be set to perform the BIT automatically and manually or manually only.

B. Principles

If the result of a BIT is the same as the current status of the detector (NORMAL or BIT FAULT), the detector's status is unchanged. If the result of a BIT differs from the current status of the detector, the detectors' status is changed (From NORMAL to BIT FAULT or from BIT FAULT to NORMAL).

Note: In BIT FAULT status, the detector can continue to detect a fire.

C. Manual BIT only

The BIT is initiated manually by momentarily connecting Terminal No. 3 with Terminal No. 2. A successful manual BIT activates the following:

- FAULT relay is closed.
- ALARM relay is activated for 3 sec (only when Function Alarm BIT at YES)
- 4-20 mA OUTPUT current will be 15mA only when Function Alarm BIT at YES

Unsuccessful BIT activates the following:

- FAULT relay is released.
- 4-20 mA output indicates BIT FAULT condition (2 mA).
- POWER LED (yellow) flashes (4 Hz).

Note:

During a MANUAL BIT, if function 'Alarm BIT' is in 'YES' position, the ALARM relay will be activated. Therefore, automatic extinguishing systems or any external devices that should not be activated during BIT should be disconnected.

D. Automatic & Manual BIT

Manual Bit

Functions as described in paragraph 4.4.c. In the case of an unsuccessful BIT all outputs will function as described in paragraph 4.4.c, but the BIT will be automatically executed every 1 minute. This mode of operation will continue until successful BIT has been encountered. As a result, the detector will resume its normal operation.

Automatic BIT

The detector automatically performs a BIT every 15 minutes.

A successful BIT sequence does not activate any indication:

The FAULT relay is CLOSED (NORMAL).

The POWER LED is ON (NORMAL).

An unsuccessful BIT sequence activates the following:

The FAULT relay	is opened
4-20mA output	indicate BIT FAULT (2 mA)
The POWER LED (yellow)	flashes (4 Hz)
BIT procedure	will be performed every 1 minute

5. Technical Specifications

5.1 Electrical Specifications

- A. **Operating Voltage:** 18-32 VDC
- B. **Power Consumption:**
 Max. 150mA in Stand-by
 Max. 200mA in Alarm
- C. **Electric input protection:** The input circuit is protected against voltage-reversed polarity, voltage transients, surges and spikes according to MIL-STD-1275A.
- D. **Electrical Interface:**

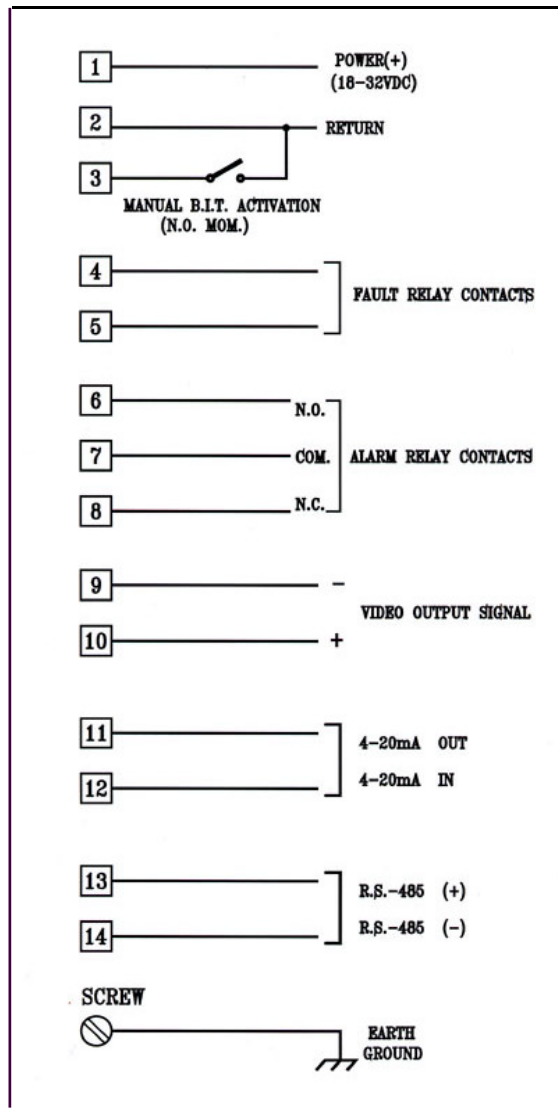

Figure 6: Electrical Interface

E. Electrical outputs

- **Dry Contact Relays:**

Table 11: Contact Ratings

Relay Name	Type	Normal position	Maximum Ratings
Alarm	SPDT	N.O. N.C.	2A at 30VDC or 0.5A at 250 VAC
Fault*	SPST	N.C.	5A at 30VDC or 250 VAC

* The FAULT relay will be normally energised closed during Normal operation of the detector. The contact will open at 'Fault' condition or low voltage.

- **4-20mA Current Output**

Terminals 11 and 12:

FAULT	0 + 0.5mA
BIT FAULT	2mA±10%
NORMAL	5mA±10%
WARNING	10mA±5%
ALARM	15mA±5%

- **Communication Network:**

The detector is equipped with an RS-485 communication link that can be used in installations with computerized controllers.

The communicator protocol is compatible with the Modbus communicator protocol.

- This protocol is a standard and widely used.
- It enables continuous communication between a single standard Modbus controller (Master device) and a serial Network of up to 247 detectors.
- It enables connection between different types of Spectrex detectors or other Modbus devices to the same Network.

- **CCTV Output**

The video output is a standard port with two options:

- Detector model No. 20/20 CTIN is a NTSC version
- Detector model No. 20/20 CTIP is a PAL version

The output can be connected to standard video accessories such as a switching box.

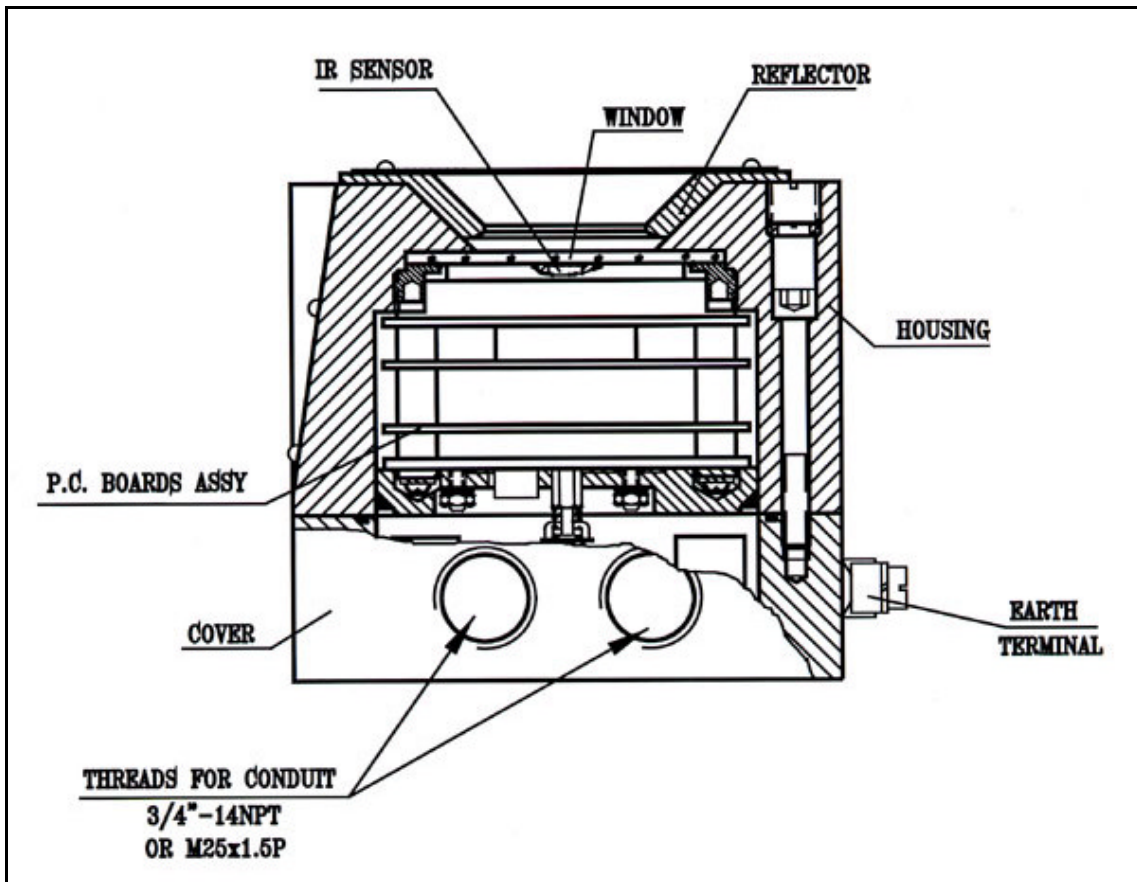

Figure 7: Flame Detector Assembly - Schematic Section

5.2 Mechanical Specifications

A. Enclosure

Aluminum: Chromate coating and Epoxy enamel finish

or

Stainless Steel 316: Electrochemical passivated coating

B. Explosion proof

ATEX	Ex II 2G SIRA 00ATEX 1163, 1164
	EExd IIB + H ₂ T5 Temp. -40°F (-40 °C) to 160°F (70 °C) Option: -40°F (-40 °C) to 185°F (85 °C) Per EN 50014 & EN 50018
	EExde IIB + H ₂ T5 Temp. -40°F (-40 °C) to 160°F (70 °C) Per EN 50014, 50018 & 50019 (see Appendix D)
UL	Class I, Groups C and D
GOST R	1ExdIIBT5/H ₂
FM	Class I Div. 1 Groups B, C and D;
(Design to Meet)	Class II Div. 1 Groups E, F and G.

C. Water and dust tight

NEMA 250 type 6p.

IP 66 and IP 67 per EN 60529

D. Electronic Modules

Conformable coating.

E. Electrical connection (two positions)

Standard 3/4"-14NPT conduit

Optional M25 x 1.5 (ISO).

F. Dimensions

Base: 5.2 x 5.2 in (132 cm x 132 cm)

Height: 4.7 in (120 cm)

G. Weight

8.1 lbs. (3.7 Kg) – Aluminum Alloy

14.3 lbs. (6.5 Kg) – ST.ST 316

5.3 Environmental Specifications

A. High Temperature

Design to meet MIL-STD-810C, method 501.1 procedure II

Operating temperature: +160 °F (+70 °C)

Optional operating temperature: +185 °F (+85 °C)

Storage temperature: +185 °F (+85 °C)

B. Low Temperature

Design to meet MIL-STD-810C, method 502.1, procedure I

Operating temperature: -40 °F (-40 °C)

Storage temperature: -65 °F (-55 °C)

C. Humidity

Design to meet MIL-STD-810C, method 507.1, procedure IV

Relative humidity of up to 95% for the operational temperature range.

D. Salt Fog

Design to meet MIL-STD-810C, method 509.1, procedure I

Exposure to a 5% Salt Solution Fog for 48 hours.

E. Dust

Design to meet MIL-STD-810C, method 510.1, procedure I

Exposure to a dust concentration of 0.3 frames/cubic ft. at a velocity of 1750 fpm, for 12 hours.

F. Vibration

Design to meet MIL-STD-810C, method 514.2, procedure VIII

Vibration at an acceleration of 1.1g within the frequency range of 5-30 Hz, and an acceleration of 3g within the frequency range of 30-500 Hz.

G. Mechanical Shock

Design to meet MIL-STD-810C, method 516.2, procedure I

Mechanical Shock of 30g half-sin wave, for 11 msec.

6. Installation Instructions

6.1 Scope

The "Spectrex" Model 20/20CTIN-CTIP is a self-contained Optical Flame Detector, designed to operate as a stand-alone unit directly connected to alarm systems or automatic fire extinguishing systems. The detector can form part of a more complex system where many detectors and other devices are integrated through a common control unit. This chapter does not attempt to cover all of the standard practices and codes of installation. Rather, it emphasizes specific points of consideration and provides some general rules for qualified personnel. Wherever applicable, special safety precautions are stressed.

6.2 General Considerations

Very Important

The detector should be aimed toward the center of the detection zone and have a completely unobstructed view of the protected area. Whenever possible, the detector face should be tilted down at a slight angle to prevent the accumulation of dust and dirt. Do not start an installation unless all conceivable considerations regarding detector location have been taken into account.

To ensure optimal performance and an efficient installation, the following guidelines should be considered:

A. Sensitivity

To determine the level of sensitivity, the following issues should be considered:

- Size of fire at determined distance to be detected.
- Type of flammable materials.

B. Spacing and Location

The number of detectors and their locations in the protected area are affected by:

- Size of the protected area
- Sensitivity of the detectors
- Obstructed lines of sight
- Cone of view of the detectors

C. Environment

- Dust, snow or rain can reduce the detectors sensitivity and require more maintenance activities.
- The presence of high intensity flickering of IR sources may affect sensitivity.

6.3 Preparations for Installation

Installation should comply with NFPA 72E, as applicable to flame detectors as required. The detectors can be installed with the use of general-purpose common tools and equipment.

- 1 Verify the appropriate Purchase Order. Record the Part No. and the Serial No. of the detectors and the installation date in an appropriate Log-book.
- 2 Open the container package prior to detector installation and visually inspect the detector.
- 3 Verify that all components required for the detector installation are readily available before commencing the installation. In case that the installation is not completed in a single session, secure and seal detectors and conduits.
- 4 For wiring, use color-coded conductors or suitable wire markings or labels. 12 to 20 AWG wires may be used for site wiring. The selection of wire gauge should be based on the number of detectors used on the same line and the distance from the control unit, in compliance with specifications (See Appendix A).

6.4 Conduit Installation

- 1 To avoid water condensation water in the detector, it should be installed with the conduits placed downward, and should include drain holes.
- 2 When using the optional swivel mount, use flexible conduits for the last portion connecting to the detector.
- 3 For installations in atmospheres as defined in Group B of the NFPA 72E, conduits inlets should be sealed.
- 4 When pulling the cables through the conduits, ensure that they are not tangled or stressed. Extend the cables about 12 in. (30 cm.) beyond the detector location to accommodate wiring after installation.
- 5 After the conductor cables have been pulled through the conduits, perform a continuity test.

6.5 Detector Mounting

The detector may be mounted on a simple fabricated bracket, or preferably the optional Swivel Mount, Model 20/20-003. The Swivel Mount enables the detector to be rotated up to 40 degrees in all directions.

6.5.1 Swivel Mount Kit:

Table 12: Mounting according to US Version

Item	Qty.	Type/Model	Location
Swivel Mount	1	20/20-003	
1/4"-20UNC Screw	4	1/4" –20UNC	Detector - Holding plate
1/4" Spring Washer	4	1/4"	Detector - Holding plate

Table 13: Mounting according to EU Version

Item	Qty.	Type/Model	Location
Swivel Mount	1	20/20-003-1	
Screw	4	M6 X 1P	Detector - Holding plate
Spring Washer	4	M6	Detector - Holding plate

6.5.2 Swivel installation (Figs. No. 8 and 9):

- 1 Place the swivel mount (item 6) in its designated location and secure it with four (4) M6 or 1/4" screws (item 11) (recommended), placed 3.0 in. (76.2 mm.) apart on the swivel mount plate (item 10).

Note: Skip this step if the Swivel Mount is already installed. Also detector removal for maintenance purpose does not require Swivel Mount removal.

- 2 Unpack the detector.
- 3 Place the detector, with its conduit inlets / electrical entries pointing down, on the holding plate of the swivel mount (item 7). Secure the detector by four (4) 1/4"-20UNC (or M6) screws with 1/4" (or M6) spring washers from the Swivel Mount Kit (using the holes (item 5)). Use 3/16 Hex Key for 1/4" screws and No. 5 for M6 screws.
- 4 Tighten the three locking 3/8"-24UNF screws (item 8) of the swivel mount ring until the friction in the ball joint holds the detector in its position, maintaining the ability to be moved by hand-applied force (Use 3/16" HEX KEY).
- 5 Point the detector towards the protected area and make certain that the view of the area. Secure the detector in that position by tightening the locking screws (item 8) of the swivel mount ring.

The detector is now correctly located and aligned and ready for connecting to the system.

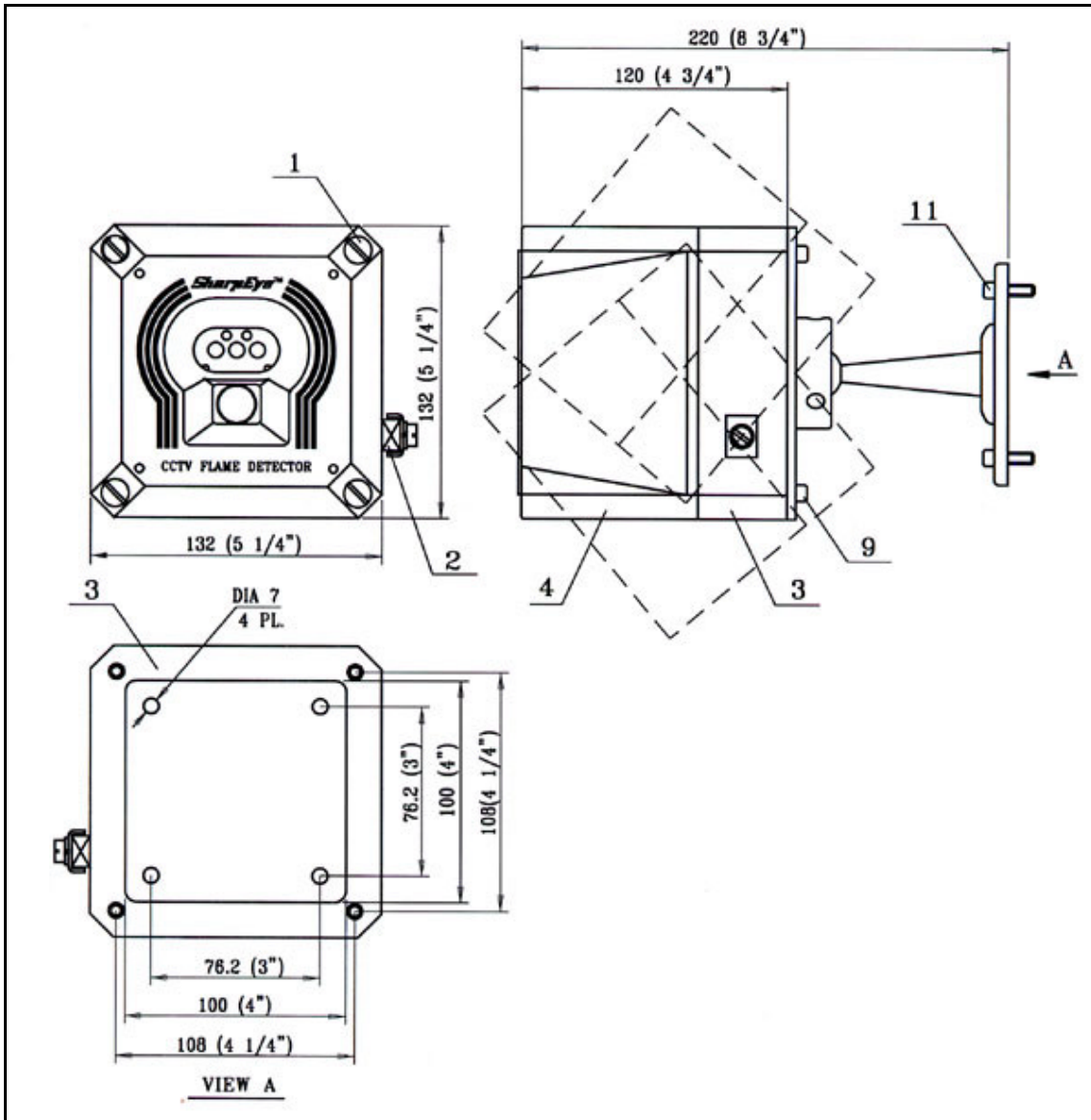
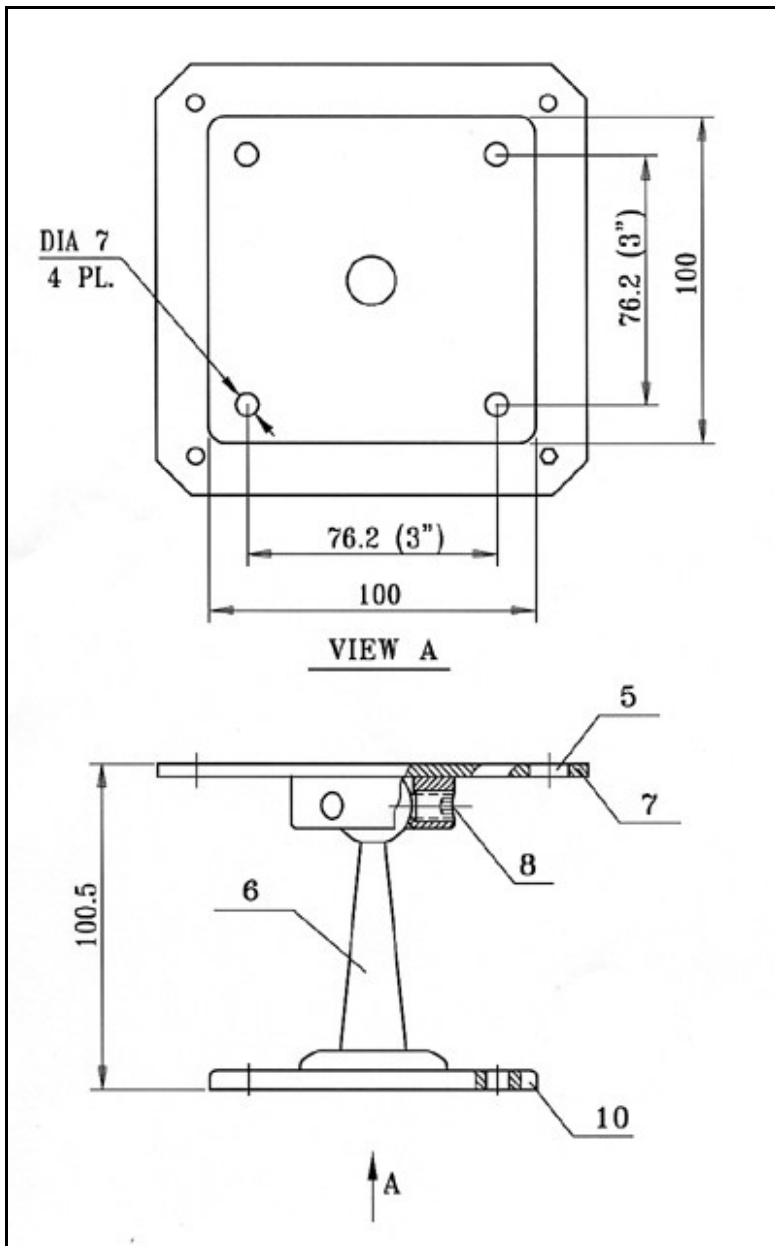

Figure 8: IR3 Detector and Swivel Mount Assembly



Description	
1	Protective Set Screws
2	Ground Terminal (for ATEX) or Ground Thread (for FM)
3	Back Cover
4	Housing
5	Swivel Mount Screw Hole
6	Swivel Mount
7	Holding Plate
8	Locking Screws
9	Detector Mounting Screws
10	Swivel Mount Plate
11	Swivel mounting screws

Figure 9: Swivel Mount Assembly - Outline Drawing

6.6 Wiring (Refer to Fig. 11)

- 1 Disconnect power.
- 2 Remove the four (4) protective set-screws from detector front. (Fig. 8 Item 1)
- 3 Release the four (4) socket-head screws that secure the detector housing (Item 1) to its back cover (Item 4) Using HEX KEY No. 5. Hold the housing (Item 1) during the removal of the screws. With the screws removed, pull the detector housing (Item 1) from its cover (Item 4). The Terminal Board inside the detector cover is now revealed.
- 4 Remove the protective plug mounted on the detector conduit inlet / electrical entry, pull the wires through the detector cover (Item 4) and secure them firmly to the cover using the cable -clamp (Item 2) attached to it. Use a 3/4"-14NPT or M25x1.5 explosion-proof conduit /cable gland connection to assemble the conduit / cable to the detector.
- 5 Connect the wires to the required terminals (Item 3) according to the wiring diagram. See paragraph 6.7.
- 6 Connect the grounding wire to the ground screw outside the detector cover (Fig. 8 item 2).

The detector must be well grounded to *Earth Ground* for proper operation.

- 7 Verify the wiring. Improper wiring may damage the detector.
- 8 Check the wires for secure mechanical connection and press them neatly against the terminal board to prevent them from interfering while closing the detectors' housing.

6.7 Terminal wiring (See Fig. No.10 and No.11.)

The detector contains a Terminal Board consisting of two (2) terminal blocks (Item 4). The left terminal block is labeled 1 to 7, the right terminal block is labeled 8 to 14.

The following describes the function of each electrical terminal of the detector:

- **Power Supply** (Terminal Numbers 1, 2):
Input power - Terminal No. 1.
The RETURN - Terminal No. 2.
- **Manual Bit Activation** (Terminal No. 3):
Terminal No. 3 is used for Manual BIT activation.
Manual BIT is initiated by a momentary connection of Terminal No. 3 to the power supply Return line.
- **Fault Relay** (Terminal Numbers 4, 5):
The Fault output is N.O. SPST relay at Terminals No. 4 and 5. The contacts are energised closed when the detector is in its normal operational condition.
- **Alarm Relay** (Terminal Numbers 6, 7, 8):
The Alarm output is a change over contact relay (SPDT).
Terminal No. 6 - N.O. relay contact.
Terminal No. 7 - COMMON relay contact.
Terminal No. 8 - N.C. relay contact.
- **CCTV** (Terminal Numbers 9, 10):
The CCTV output is a standard video output available at PAL or NTSC according to Model No.20/20 CTSN for NTSC and 20/20CTIP for PAL.
Terminal No. 9 - video signal (-)
Terminal No. 10 - video signal (+)

Note

To protect the dry contacts from voltage surges when connected to reactive loads (electric motors, sirens, etc.), connect an appropriate varistor over these contacts.

- **4-20mA Output** (Terminal Numbers 11, 12):
Terminal Numbers 11 and 12 are used for analog, 4-20mA current output as specified in paragraph 4.e
Terminal No. 11 - output Terminal.
Terminal No. 12 - input Terminal (see appendix B for more details)
- **RS-485** (Terminal Numbers 13, 14):
Terminal Numbers 13 and 14 are used for communication network as specified in appendix C.
Terminal No. 13 - positive (+) lead.
Terminal No. 14 - negative (-) lead.

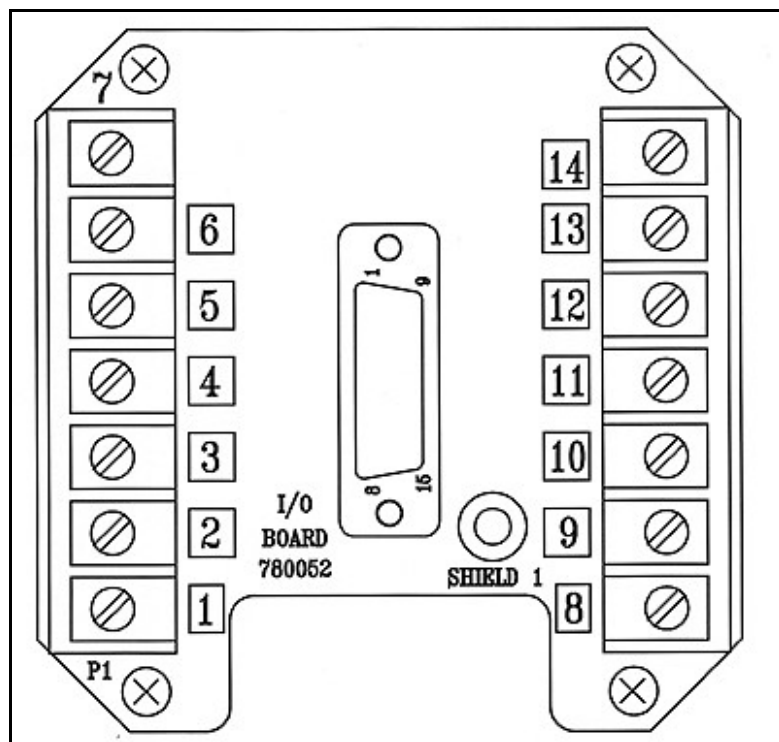
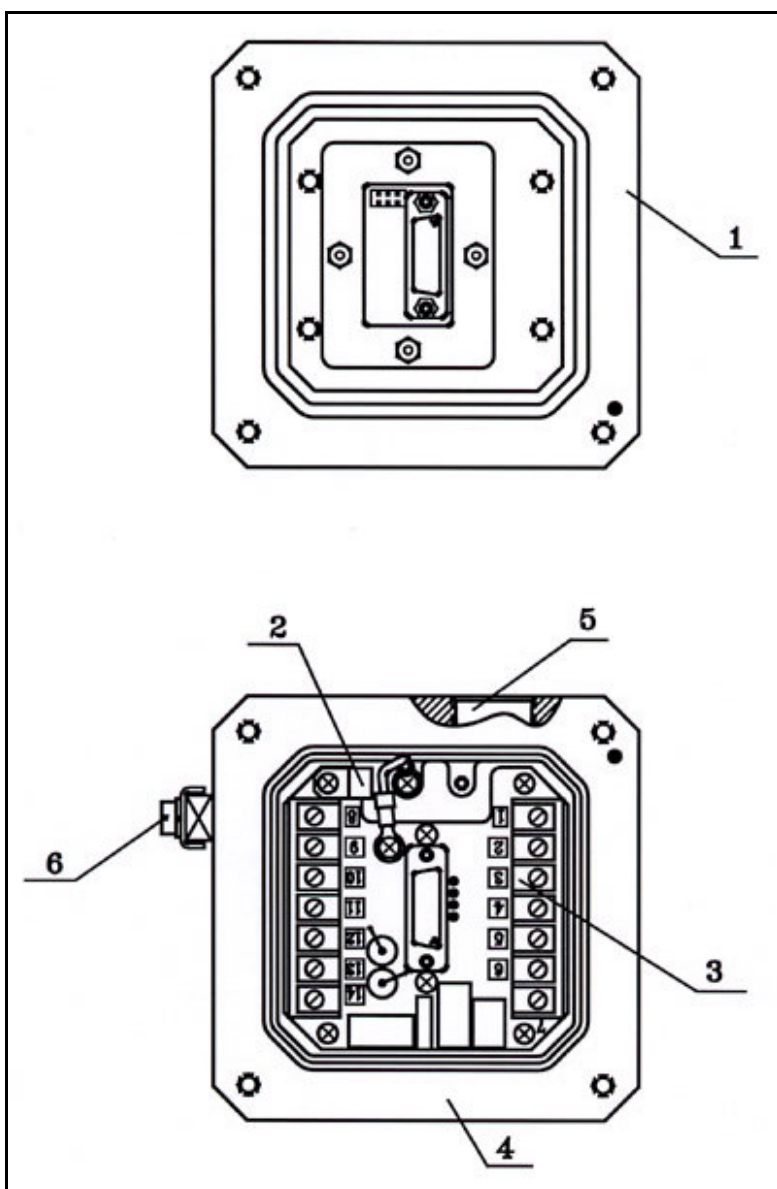

Figure 10: Terminal Board



Description	
1	Housing
2	Securing Cable
3	Terminal Board
4	Back Cover
5	Inlet Conduit
6	Earth Terminal

Figure 11: IR3 Flame Detector with cover removed

6.8 Operation Mode

When wiring is completed the operational mode can be selected.

Mode selection is achieved through RS-485 using a PC with Spectrex Host software. Refer to TM784050.

Programmable Function:

Modes of operation are programmable with a PC or Handheld unit according to the selection table in Paragraph 4.3.1 and Refer to TM 784050. Refer to here in 4.3.1 etc.

Address:

The detector has the capability of acting as an addressable device.

The detector provides 247 addresses, which can be used by the RS-485 communications link as described in paragraph 4.3.4 and Refer to TM 784050.

Alarm Delay:

An Alarm Delay may be required for certain applications. The detector has an Alarm Delay that permits time delays from 0, anti-flare, 3, 5, 10, 15, 20 and 30 seconds respectively. The delay can be defined by the RS-485. See paragraph 4.3.3 and refer to TM 784050.

7. Operating Instructions

7.1 Scope

The following instructions are designed to obtain optimal performance from the detector over its life cycle.

7.2 Power-Up

- 1 Apply power and wait approximately 60 seconds for the automatic self-test of the detector.

Note: Applying power initiates the following sequence:

- POWER LED flashes
 - BIT is executed, if successful then:
 - POWER LED turns ON continuous
 - FAULT relay contacts close
- 2 Wiring Inspection: If a short-circuit or line discontinuity exists, indications will appear on the control unit display panel. Review your wiring.
 - 3 The detector goes into its FAULT state when supply voltage drops under 16.5V. The detector status goes back to NORMAL, when the supply voltage is above 17.5V.
 - 4 Detector Inspection: Visually inspects the viewing window of the detector. It should be clean and clear. The POWER LED should be ON and the ALARM LED should be OFF. The ALARM should be OFF and the FAULT relay should be ON. The 4 -20mA Output should be 5mA.
 - 5 If any of the outputs or indications is different from the description in step 4, see paragraph 8.6.1 for troubleshooting.

The Flame Detector is now ready for Functional Testing.

7.3 Reset

If the optional alarm latching mode has been selected, RESET of a detector, when in its ALARM state, can be activated by disconnecting power (terminal No. 1 or terminal No. 2), or initiating a manual BIT.

7.4 Functional testing

Following is a test procedure for proper functioning of the detector. The detector can be tested using the Manual Built-in-Test (BIT) or the Spectrex IR3 Fire Simulator - 20/20-310

7.4.1 Manual BIT Test

Important Note!

If the function setup “Alarm BIT” is in YES, then the Alarm and 4-20mA Output will be activated during a manual BIT, therefore, automatic extinguishing systems or any external devices that may be activated during BIT must be disconnected.

- 1 Verify that the detector is operating properly.
- 2 Initiate manual BIT. After a few seconds the following occurs:
 - Alarm Relay will be activated and the 4-20mA output turns to 15mA for 3 seconds (only if “Alarm BIT” at YES).
 - The CCTV will be activated and the 4-20mA output turns to 10mA for 3 seconds (only if “Accessory BIT” at YES).
 - The 2 LEDs should be ON.
 - Fault Relay will stay active during the test.

7.4.2 Testing with fire simulator

This test simulates an exposure of the detector to a real fire condition. The detector is exposed to the radiation in the specified detection level. As a result the detector must generate a Fire Alarm signal.

Important Note!

If the detector is exposed to a fire simulator, the Alarm Relay and 4-20mA will be activated during the simulation. Therefore, automatic extinguishing systems or any external devices, which may be activated during this process, must be disconnected.

- 1 Apply power to the system and wait up to 60 seconds for turning of the detector to normal state. Power led turns on. If the detector is on, skip this step.
- 2 Aim the Spectrex Fire Simulator Model 20/20-310 at the target point of the detector (see Fig. 22), in a way that the radiation emitted by it is facing directly towards the detector. (See appendix E)
- 3 Press the operation button once. After a few seconds the Alarm LED should be ON for a few seconds. The 4-20mA output should turn to 15mA for a few seconds and then return to 5mA. The Alarm Relay should also turn on during this period. The CCTV will operate in parallel to the Alarm Relay if “Accessory BIT” at YES.

This completes the installation procedure. The detector and system are now ready for operation.

7.5 Safety Precautions

After Powering-up, the detector requires hardly any attention in order to function properly, but the following should be noted:

- 1 Follow the instructions in the manual and refer to the drawings and specifications issued by the manufacturer.
- 2 Do not expose the detector to radiation of any kind unless required for testing purposes.
- 3 Do not open the detector housing, while power is supplied.
- 4 Do not touch internal parts. Interference with internal circuits may impair detector performance and will invalidate manufacturer's Warranty.
- 5 Disconnect external devices, such as automatic extinguishing systems before carrying out any maintenance.

8. Maintenance Instructions

8.1 Scope

This chapter deals with preventive maintenance, describes possible faults in detector operation and indicates corrective measures. Ignoring these instructions may cause problems with the detector and may invalidate the warranty. Whenever a unit requires service, please contact the manufacturer or its authorized distributor for assistance.

8.2 Maintenance Instrumentation and Personnel

The detectors' maintenance requires ordinary tools and qualified personnel, who should be familiar with local codes and practices.

8.3 Preventive Maintenance Procedures

The detector must be kept as clean as possible. The viewing window and the reflector of the 20/20CTIP and 20/20CTIN Flame Detector Models must be cleaned on a periodic basis. The frequency of cleaning operations depends upon the environmental conditions and specific applications. The fire detection system designer will give his recommendations. Use of the optional AIR SHIELD Model 20/20-920 is highly recommended and will help to keep the window clean and prevent dirt from accumulating on the window.

- 1 Disconnect power to the detector before proceeding with any maintenance including lens cleaning.
- 2 To clean the detector viewing window and reflector use water and detergent, rinse with clean water.
- 3 Where dust, dirt or moisture accumulates on the window, first clean with a soft optical cloth and detergent, then rinse with clean water.

8.4 Periodic Maintenance Procedures

In addition to preventive cleaning and maintenance, the detector should be functionally tested every six months. This test should also be carried out for any reason the detector has been opened.

8.4.1 Power-Up Procedure

Perform Power-Up procedure every time power is restored to the system. Follow the instructions in paragraph 7.2.

8.4.2 Functional Test Procedure

Perform a functional test of the detector as described in paragraph 7.4.

8.5 Maintenance Records

It is recommended to record maintenance operations performed on a detector in a system Log-book. The record should include information, which identifies the unit, the installation date, contractor, and entries for every maintenance operation performed including the description of the operation, date and personnel ID.

If a unit is sent to the manufacturer or distributor for service, a copy of the Maintenance records should accompany it.

8.6 Troubleshooting

8.6.1 Fault Indication

- 1 Check power supply for correct voltage, polarity and wiring.
- 2 Check detector window and reflector for cleanness. If necessary clean the window as indicated in paragraph 8.3 and repeat the test.
- 3 Disconnect the power supply to the system and check the detector's internal wiring.
- 4 Reconnect power supply and wait approximately 60 seconds. Repeat the test. If the indication LED is still flashing, the unit requires service.

8.6.2 False Alarm or Warning Indication

- 1 Disconnect the power supply from the system and check internal wiring.
- 2 Reconnect power supply and wait approximately 60 seconds. If indication remains, the unit requires service.

Appendix A - Wire Selection Tables

General Instructions For Electrical Wiring

1. Refer to Table 14 to determine the required wire gauge for general wiring, such as relay wiring. Calculate the permitted voltage fall with respect to loads current, wire gauge and length of wires.
2. Refer to Table 15 to select wire gauge for power supply wires. DO NOT connect any circuit or load to detectors' supply inputs.

Table 14: Maximum DC resistance at 68 F for copper wire

AWG #	mm ²	Ohm per 100 ft.	Ohm/100 meter
26	0.12 - 0.15	4.32	14.15
24	0.16 - 0.24	3.42	11.22
22	0.30 - 0.38	1.71	5.60
20	0.51 - 0.61	1.07	3.50
18	0.81 - 0.96	0.67	2.20
16	1.22 - 1.43	0.43	1.40
14	1.94 - 2.28	0.27	0.88
12	3.09 - 3.40	0.17	0.55
10	4.56 - 6.64	0.11	0.35

- A. Select "Number of detectors" connected in one circuit.
- B. Select "wiring length" per your installation requirements.
- C. Refer to "power supply range" for voltage extreme applied.

Table 15. Wiring length in feet (meter)

No. of Detectors	Recommended Wire Diameter (AWG)					Power Supply Range (VDC)
24	18	16	14	-	-	22-32
20	18	16	14	-	-	22-32
16	20	18	16	14	-	22-32
12	20	18	16	14	-	20-32
8	20	18	16	14	-	20-32
4 and less	20	18	16	16	14	20-32
Feet (meter)	164 (50)	328 (100)	492 (150)	656 (200)	820 (250)	
	Max. Length from Power Supply to Last Detector					

CCTV Wire Type

The wire for the video picture must be Twisted Pair Wire.

Network Wiring	UTP
Wire Gauge	24 AWG or thicker
Category Type	2, 3, 4, 5 or better
Impedance	100±20 ohms
DC Loop Resistance	52 ohms per 1,000ft/300m
Differential Capacitance	19pF/ft max

Appendix B – Typical Wiring Configurations

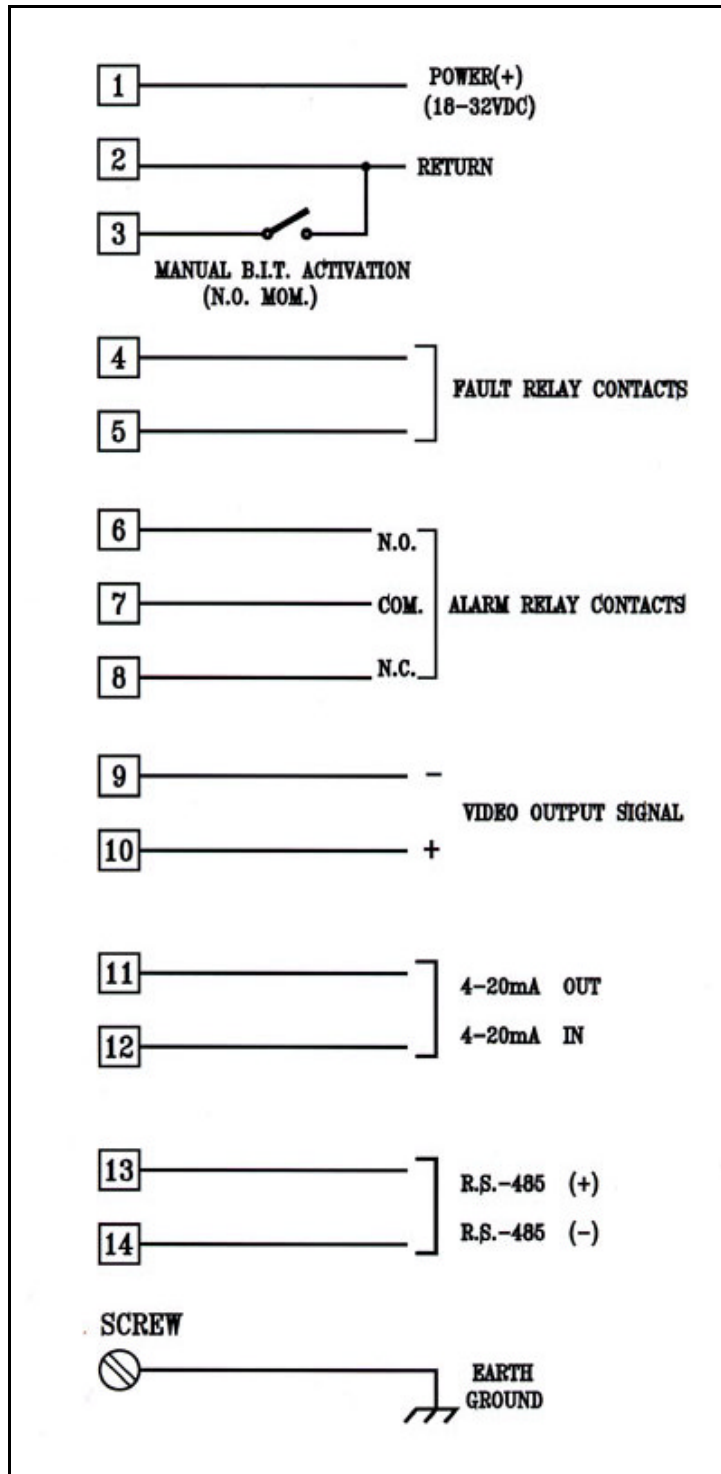

Figure 12: Flame Detector Wiring Diagram

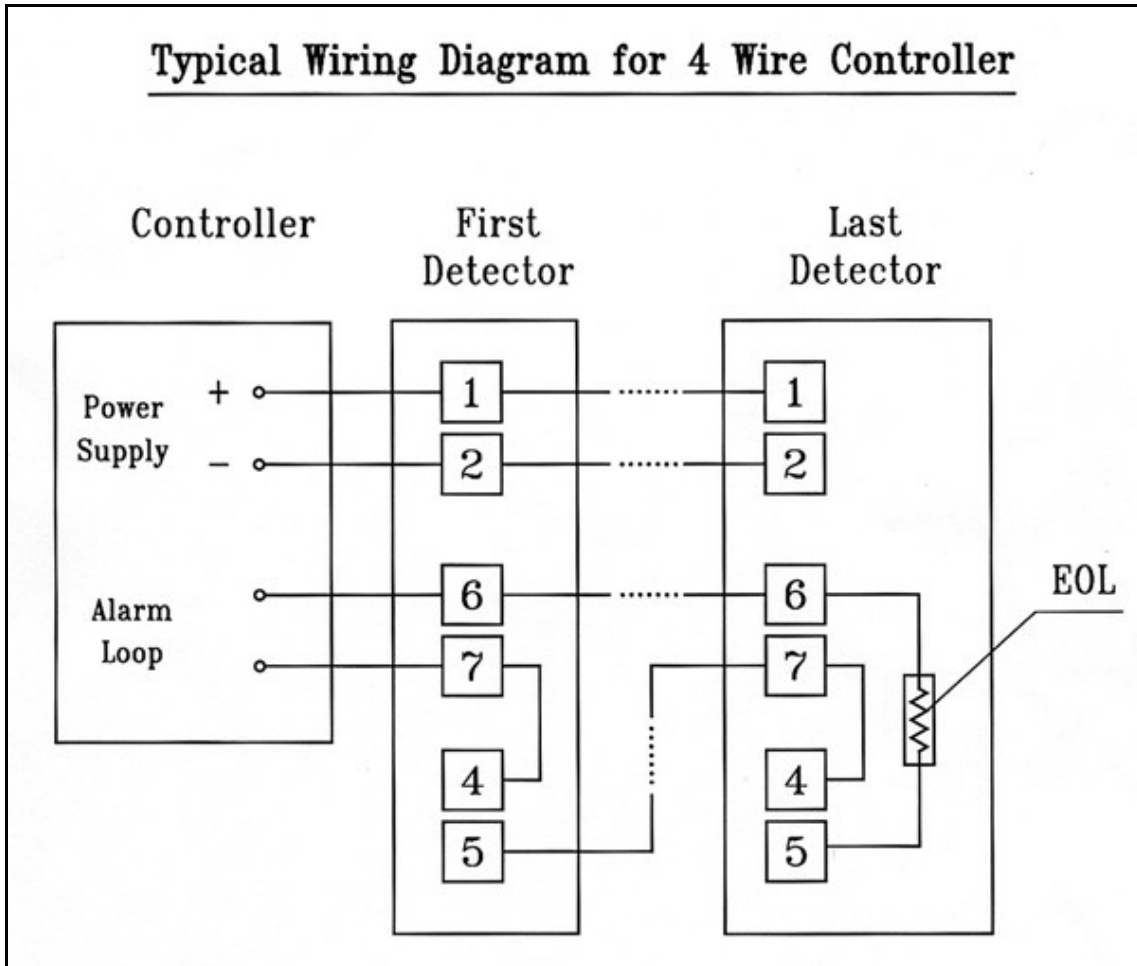

Figure 13: Typical wiring diagram for 4 wire controllers

Notes: For EOL Resistors Values See Controller Manual

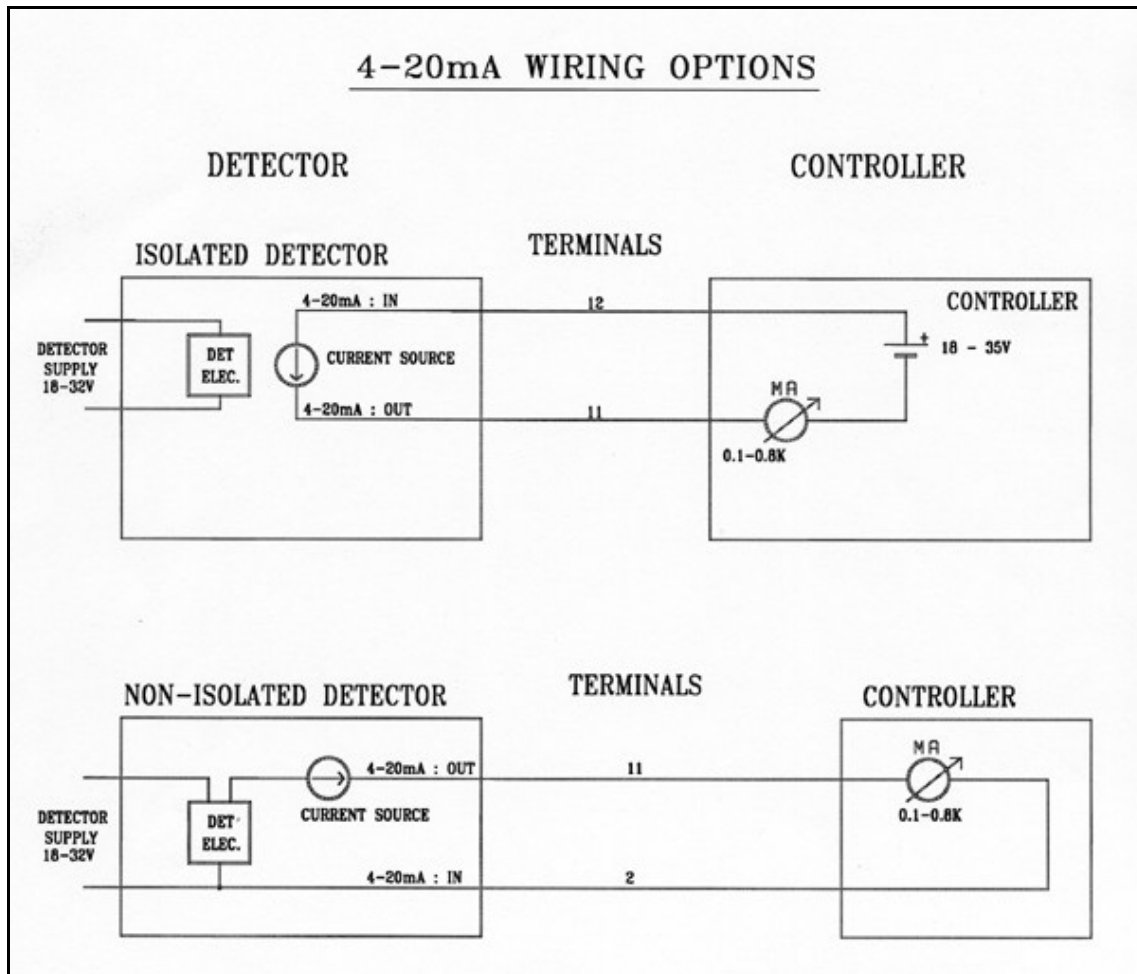

Figure 14: 4-20mA wiring

Notes:

The detectors are factory set to isolated 4-20mA 'sink' version.

To work at non-isolated 4-20mA version (source), connect Terminal 12 to Terminal 1. The 4-20mA meter is connected between Terminal 11 and Terminal 2.

CCTV Wire Type

The wire for the video picture must be Twisted Pair Wire.

Network Wiring	UTP
Wire Gauge	24 AWG or thicker
Category Type	2, 3, 4, 5 or better
Impedance	100±200 ohms
DC Loop Resistance	52 ohms per 1,000ft (300m)
Differential Capacitance	19pF/ft max

The Twist Pair must be connected to a PASSIVE or ACTIVE receiver depending on the length cable from the CCTV to the receiver.

0 - 1000 ft (300m)	Require PASSIVE receiver
660 - 3300 ft (200m - 1000m)	

The connection from the receiver should be made by coax cable connected to the monitor or through a switching box when connecting two (2) or more CCTVs to the same monitor.

Appendix C – RS-485 Communication Network

Using the RS-485 network capability of the IR3 detector and additional software it is possible to connect up to 32 detectors in an addressable system with 4 wires only (2 for power & 2 for communication). Using repeaters, the number of detectors can be much larger (32 detectors for each repeater) up to 247 on the same 4 wires. When using the RS-485 network it is possible to read each detector status (FAULT, WARNING, ALARM) and to initiate a BIT to each detector individually.

Fore more details, consult the factory.

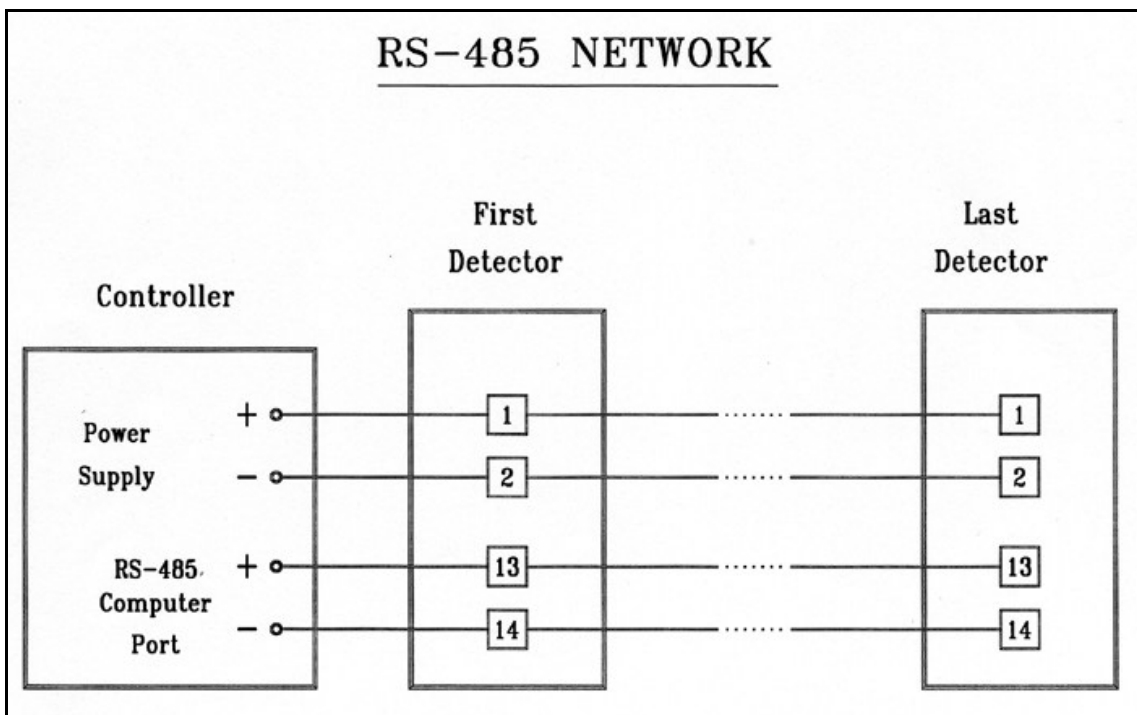

Figure 15: RS-485 networking

Appendix D - Mounting the “EExde approved” version

The EExde approved version provides an additional EExe terminal box attached below the EExd detector and therefore allows easier access for wiring in difficult environments and hazardous areas (see fig. 18). The unit is prewired to the terminals in the additional EExe terminal section ready for field wiring connections

1. Detector Mounting

The detector may be mounted on a simple fabricated bracket, or preferably the optional Swivel Mount, Model 20/20-003. The Swivel Mount enables the detector to be rotated up to 40 degrees in all directions.

1.1 Swivel Mount Kit - Use the kit from the paragraph 6.5.1

1.2 Swivel installation

- 1 **Refer to Fig.8 and Fig 9.** Place the swivel mount (item 6) in its designated location and secure it with four (4) M6 or 1/4" screws (item 11) (recommended), placed 3.0 in. (76.2 mm.) apart on the swivel mount plate (item 10).

Note: Skip this step if the Swivel Mount is already installed. Also detector removal for maintenance purpose does not require Swivel Mount removal.

- 2 Unpack the detector.
- 3 Place the detector, with its conduit inlets / electrical entries pointing down, on the holding plate of the swivel mount (Fig. 8 item 7). Secure the detector by four (4) M6 screws with M6 spring washers from the Swivel Mount Kit using the holes (Fig. 9 item 5). You can use the thread on the modified cover (Fig. 18 item 1) marked either triangle symbol or square symbol. Use No. 5 Hex Key for M6 screws.
- 4 Tighten the three locking 3/8"-24UNF screws (Fig. 9 item 8) of the swivel mount ring until the friction in the ball joint holds the detector in its position. Yet, still permits it to be moved by hand-applied force (Use 3/16" HEX KEY).
- 5 Point the detector towards the protected area and make certain that the view of the area. Secure the detector in that position by tightening the locking screws (Fig.9 item 8) of the swivel mount ring.

The detector is now correctly located and aligned and ready for connecting to the system.

2. WIRING (REFER TO FIG. 18.)

- 1 Disconnect power.
- 2 Release the four (4) slotted-head screws (item 3) that secure the chamber cover (Item 2). The chamber is now revealed.
- 3 Remove the protective plug mounted on the detector conduit inlet/ electrical entry, pull the wires through the detector chamber (Item 7). Use a 3/4"-14NPT or M25x1.5 explosion-proof conduit / cable gland connection to assemble the conduit / cable to the detector.
- 4 Connect the wires to the required terminals (Item 4) according to the wiring diagram. See paragraph 2.1 and figures no. 19 and no. 20.
- 5 Connect the grounding wire to the ground screw outside the detector cover (Item 5).

The detector must be well grounded to *Earth Ground* for proper operation.

- 6 Verify the wiring. Improper wiring may damage the detector.
- 7 Check the wires for secure mechanical connection and press them neatly against the terminal to prevent them from interfering while closing the cover (Item 2).
- 8 Place and secure the cover chamber (Item 2) using four (4) slotted-head screws (Item 3).

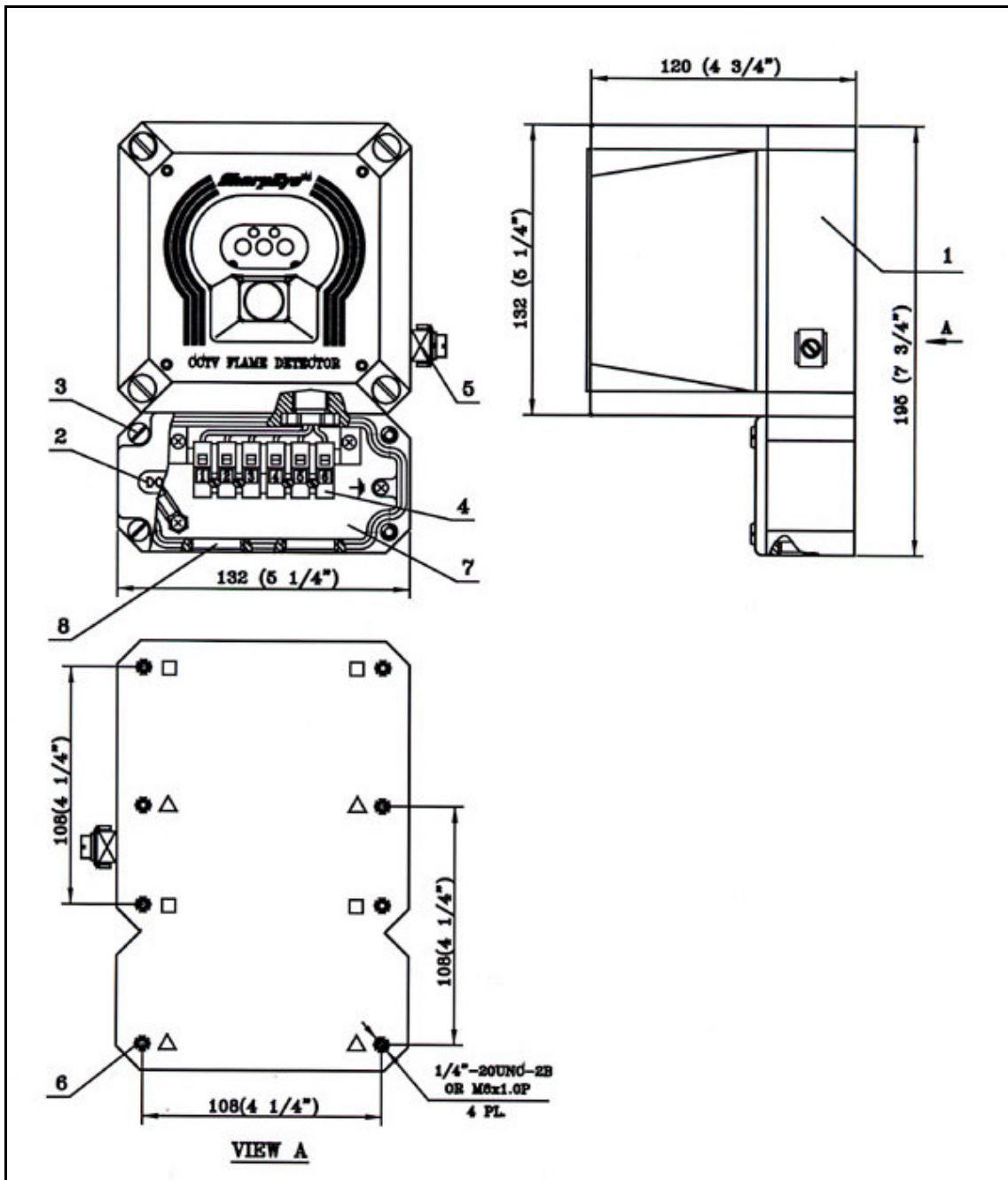

Figure 16: Flame Detector Assembly - Wiring Diagram

Description	
1. Modified Back Cover	5. Ground Terminal
2. EExe Chamber Cover	6. Mounting Thread
3. Slotted Screw	7. EExe Chamber
4. Terminal Block	8. Conduit Inlet

2.1 Terminal Wiring

The terminal block is labeled 1 to 6. (See Fig. No.18)

The following describes the function of each electrical terminal of the detector:

Power Supply (Terminal Numbers 1, 2):

Input power - Terminal No. 1.

RETURN - Terminal No. 2.

CCTV (Terminal Numbers 3, 4):

The CCTV output is a standard video output available at PAL or NTSC according to Model No. 20/20 CTSN for NTSC and 20/20 CTIP for PAL.

Terminal No. 3 - video signal (-)

Terminal No. 4 - video signal (+)

4-20 mA Output (Terminal Numbers 5, 6):

Terminal Numbers 5 and 6 are used for analog, 4-20mA current output as specified in paragraph 5.e

Terminal No. 5 - output Terminal.

Terminal No. 6 - input Terminal (see appendix B for more details)

Note

- For other ANALOG OUTPUTS consult the factory.
- The detector contains an EExe chamber consisting of a terminal block (Item 4).

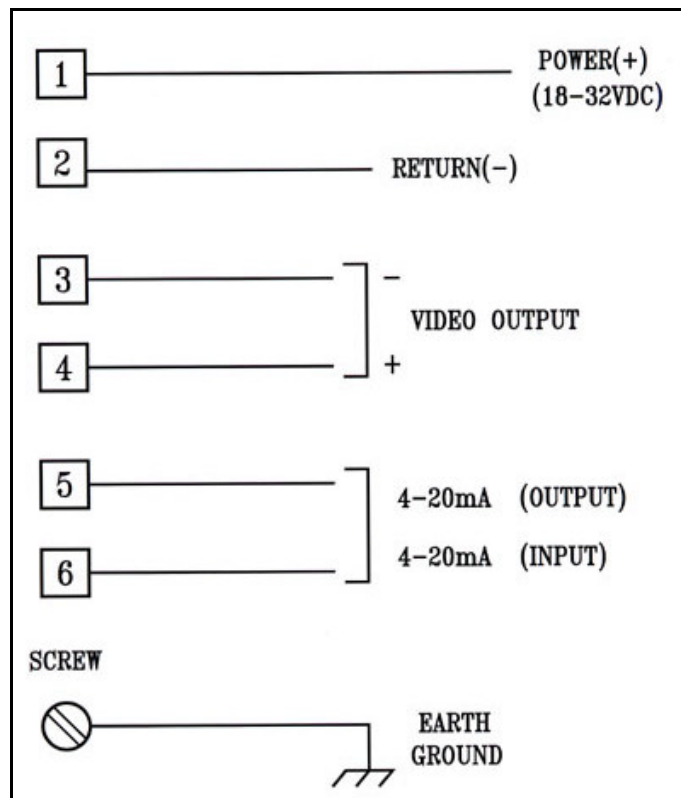

Figure 17: Flame Detector Assembly - Wiring Diagram (“de version”)

Appendix E - Long Range IR3 Fire Simulator

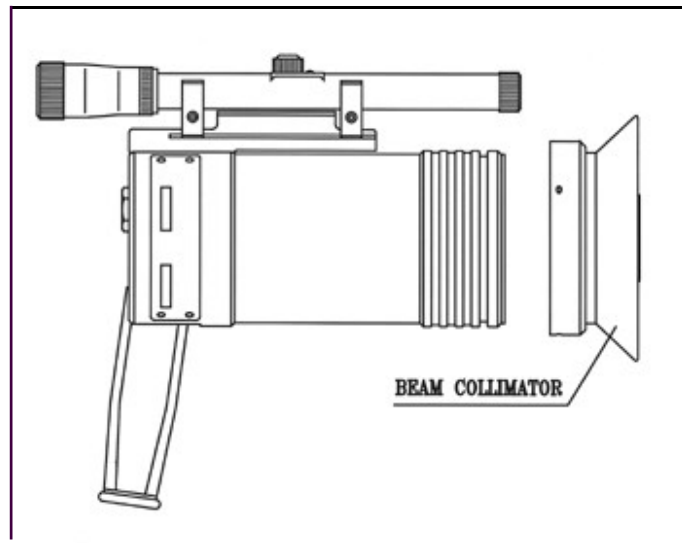

Figure 18: Fire Simulator

Product Description

The SharpEye IR3 Long Range Fire simulator 20/20-310 is designed specifically for use with the IR3 flame detectors. The Fire Simulator emits IR radiation in a unique sequential pattern corresponding and recognizable by the IR3 detector as fire. This allows the IR3 detectors to be tested under real fire conditions without the associated risks of an open flame. There is a specially designed beam collimator model number 20/20-190 used for extended range.

Unpacking

In addition to the delivery form, there should be the following contents:

- Fire Simulator with built in batteries
- Battery charger
- Optional Beam Collimator
- Storage Case

Operating Instructions

WARNING:

Do not open the Fire Simulator to charge the batteries or for any other reason in a hazardous area.

CAUTION:

The following test will simulate a real fire condition and may activate the extinguishing system or other alarms. If this is not desired, disconnect them before the test and reconnect after the simulation.

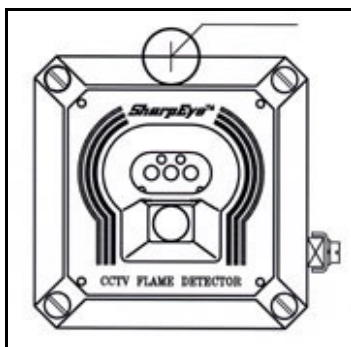

Figure 19: IR3 Detector Target Point

Follow these instructions to simulate a fire:

1. Aim the Fire Simulator towards the detector's "Target Point".
2. For testing keep a distance of at least 20 inches (50cm) from the detector.
3. Press the operation button once. Fire simulation will last for 20 seconds. The detector will send an alarm signal (solid red LED).
4. For another fire simulation a 20 second time lapse is required between tests.
5. Make sure the optical window is clean and keep the Fire Simulator in a safe place when not in use.

Battery Charging

The Fire Simulator uses NiCad batteries as a rechargeable power source. When the batteries are fully charged it will operate for at least 60 uses without recharging. An internal buzzer is sounded when the voltage from the batteries is lower than the required operational level.

1. Place the Fire Simulator on a table in a safe area.
2. Turn the sealed plug (next to the operation button) counter-clockwise with a suitable wrench.
3. Connect the battery charger.
4. Charge for a maximum of 14 hours.
5. Disconnect the charger.
6. Tighten the sealed plug clockwise.

Specifications

Mechanical			
Explosion Proof Enclosure:			
NFPA (designed to meet)			
Class I, Division 1 & 2 Groups B, C and D			
Class II, Division 1 & 2 Groups E, F, and G			
ATEX EX II2G, NEMKO 02ATEX255			
EExd IIB T5 50 C per En 50-014 & EN50-018			
Electrical			
Power: 8 VDC Max.			
6 x Rechargeable 1.2 VDC NiCad Batteries			
Current: 2.5A Avg.			
Charge: 400mA for 14 Hours			
Environmental			
Temperature Range: -4° F (-20° C) to 122° F (50° C)			
Vibration Protection: 1g (10-50hz)			
Water and Dust: IP 67 per EN 60529			
Physical			
Dimension: 11.5 x 10.1 x 3.9 in (292 x 258 x 100 mm)			
Weight: 7.5 lb. (3.4 Kg)			
Range*			
<u>Sensitivity</u>	<u>Range</u>	<u>Standard</u>	<u>Extended Range (with Collimator)</u>
1 (Low)	50 ft (15 m)	3.8 ft (1.2 m)	7 ft (2.2 m)
2	100 ft (30 m)	7 ft (2.2 m)	14.5 ft (4.5 m)
3	150 ft (45 m)	10 ft (3.2 m)	22 ft (7.0 m)
4 (High)	200 ft (60 m)	14.5 ft (4.5 m)	29 ft (9.0 m)

* The minimum distance from the detector is 20 inches (50cm)

* At extreme temperatures - 15% Max. Reduction in range

