

MAXIM II

Overview

The *MAXIM II* Controller is a state of the art digital processing system that has the capability of controlling various types of industrial, commercial and domestic systems. The *MAXIM II* can operate as a standalone device, using its own universal inputs and analogue and digital outputs to receive information and control external equipment, or as part of a network of devices that support Global NetComms.

The *MAXIM II's* configuration program is developed on a computer using a Windows based program. This allows the user to configure the internal processes of the *MAXIM II* by using a graphical programming tool. The user places various process blocks and interconnecting lines to design the required control algorithm for the system.

A connector on the bottom right side of the case provides an RS485 serial link to the computer via a 485/232 converter for downloading the configuration program. This link may also be used to upload logged data or the program back out of the controller for modification or debugging purposes.

Features

- 100 millisecond cycle/scan time
- 6 configurable universal inputs
- 6 digital relay outputs
- 4 analogue outputs
- User interface on a 4 line, 20 character LCD Display
- 25 user defined watches
- Data logging of 512 k bytes, approx. 50 000 readings
- Status of I/O points displayed LCD
- 1 RS485 serial communications port for Net Comms
- 1 RS485 serial communications port for Global Comms
- User Selectable Baud Rates:
 - (a) Net 9600 Globals 4800 OR
 - (b) Net 57600 Globals 38400
- All wire connections by 2.5mm screw terminals
- Program resides in non-volatile Flash Ram
- Real Time Clock, battery backed for approximately 5 years

Approvals

The *MAXIM II* Controller conforms to:

- EN 55011 Class B Group 1 & EN 50082-1 for CE Marking
- AS/NZS 2064:1997 for C-Tick Labelling.
- Title 47 CFR, Part 15 Class A for FCC Marking
- UL listed to UL916, File Number E242628

MAXIM II Controller

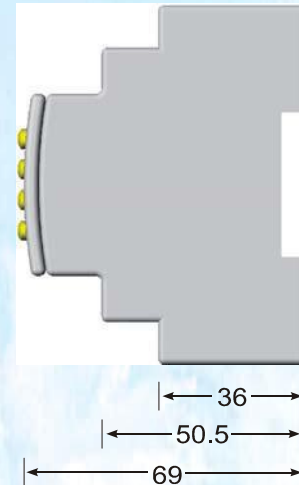
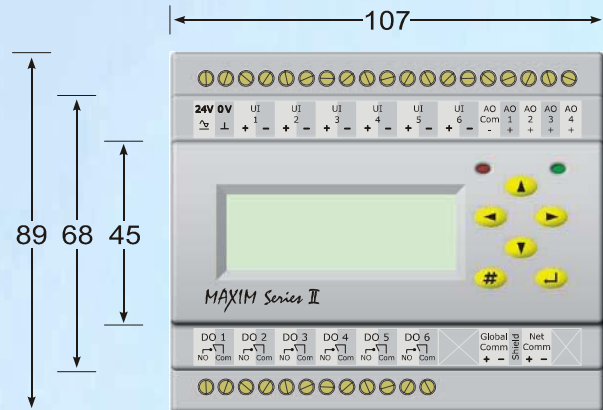

Applications

MAXIM II Controllers are designed for mounting inside a control cubicle and offers a variety of inputs and outputs enabling it to monitor and control all types of external plant and equipment. Although the *MAXIM II* is flexible, it is primarily designed for the air conditioning and building automation industry.

The small size of the *MAXIM II* also gives it the advantage of being fitted in small places without taking up valuable switch-board real-estate.

The *MAXIM II* provides all the features of a stand-alone MAXIM but with many additional features.

The creation of control strategies is made simple by the use of the MAXIM Config configuration utility. This utility with its powerful Graphical User Interface allows the user to create an entire control strategy in block-diagram form.

Typical applications include:

- Air conditioning and heating systems
- Lighting control
- Time clock controller
- Monitoring device
- Distributed I/O points controller
- Cold/Freezer Rooms



GasTech Australia Pty Ltd
24 Baretta Rd
Wangara Western Australia 6065
Tel 1800 999 902
Fax 1800 999 903
<http://www.gastech.com.au>

Specifications

Power Supply

- 24VAC \pm 10% @ 50/60 Hz.
- 24VDC \pm 10%.

Transformer nominal rating of 5VA.

The operating voltage must meet the requirements of Safety Extra Low Voltage (SELV) to EN60730. The transformer used must be a **Class 2 safety transformer** that has the energy and voltage limiting characteristics as described in the National Electrical Code, ANSI/NFPA70. It must also be sized and fused in compliance with local safety regulations.

Temperature Ratings

- Storage 0 to 50°C non-condensing.
- Operating 0 to 40°C non-condensing.

Inputs

- 6 Universal Inputs
Configurable via software to either:
Dry Digital Inputs
Voltage Digital Inputs
10K Thermistor Inputs
0-10VDC
LUX sensor input (Light sensor OR P12 LDR)
Dry Duty Cycle Inputs
Voltage Duty Cycle Inputs
Dry Pulse Counter Inputs
Voltage Pulse Counter Inputs
Exact Input combinations may be limited by the device.
- Input accuracy is \pm 0.1 volts.

Input Type	Input Range	Output Range
0-10 Volts DC	0 to 10 V DC	0 to 10 V DC
Dry Digital	Open or Closed	OFF or ON
Voltage Digital	0 to 10 V DC	OFF or ON
High Thermistor	100k to 680 ohms	-20°C to 100°C
LUX Sensor	1Meg ohm to 200 ohms	3 to 2500 LUX
Low Thermistor	662k to 12k ohms	-50°C to 20°C
Dry Duty Cycle	Open or Closed 1 to 13Hz	0 to 100% \pm 10% accuracy
Voltage Duty Cycle	0-10V Square Wave 1 to 13Hz	0 to 100% \pm 10% accuracy
Dry Pulse Counter	Open or Closed 20ms Min. ON Time 20ms Min. OFF Time	0 to 25 pulse per second \pm 1 pulse accuracy *
Voltage Pulse Counter	0-10V Square Wave 20ms Min. ON Time 20ms Min. OFF Time	0 to 25 pulse per second \pm 1 pulse accuracy *

* Error is less than 0.2% with 15Hz square wave input.

Outputs

- 6 Digital Outputs
6 x normally open relays (2 amp @ 24VAC)
Recommended use of pilot relays when switching high voltage/inductive loads
- 4 Analogue Outputs
1&2 can be configured individually as either linear 0-10VDC or PWM outputs
3&4 are dedicated linear 0-10VDC outputs
Output Load $>$ 2kOhms
- Note that up to 3 solid state relays can be connected in series, to the analogue outputs when configured as PWM.

Battery

Contains a Lithium Battery, dispose of properly.
Type CR-2032 Lithium
Nominal voltage 3 Volts
Shelf life - 5 Years dependant on ambient temperature
CAUTION: Risk of explosion if battery is replaced by an incorrect type.

Enclosure

The *MAXIM II* is housed in a rectangular case made from flame retardant polycarbonate/ABS plastic listed under UL94.

Colour: Grey
DIN Rail mounted.

Data Logging

The *MAXIM II* Controller comes with a powerful Data Logging facility. Data Logging can be assigned to hardware and software points. Approximately 50 000 time stamped readings can be stored on the *MAXIM II*. All data is stored in a 512K byte non volatile flash ram. When the memory becomes full, new readings replace the oldest readings. All logged data points can be extracted by using the MAXtract Software tool.

Communications

- RS485:
5way plug in connector for local/remote computer access for purposes of uploading, downloading and monitoring configuration programs and the extraction of logged data, via a 485/232 converter.

MAXIM Model Number Designations:

	Series	Logging Memory	Display
MAX	2	L	N
MAX	2	L	D



GasTech Australia Pty Ltd
24 Baretta Rd
Wangara Western Australia 6065
Tel 1800 999 902
Fax 1800 999 903
<http://www.gastech.com.au>

User Interface

For ease of use the *MAXIM II* Controller is provided with a 4 line, 20 character Liquid Crystal Display and Keypad. Keypad consists of six navigational push buttons to provide input into the system. These buttons are "Up", "Down", "Left", "Right", "Enter", "Escape". Using these buttons, the user can gain access to the menu structure as shown below.

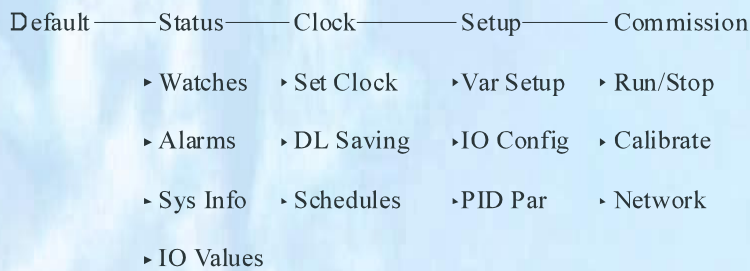

The Display has up to 5 programmable watch pages with user defined watch page description, each page displaying 5 points of information, and allows access to the status of all IO values and system information. The user can set clock/schedules variables and calibrate inputs. All information displayed on the display is in English and standard engineering units.

Associated Software

MAXCon - *MAXIM II* Controller Configuration utility. It allows the user to internally configure a *MAXIM II* by a simple point-and-click approach on a PC running Windows.

MAXMon - The *MAXIM* Monitor is a monitoring and debugging utility designed to help with commissioning and trouble-shooting a *MAXIM II* Controller. It displays the configuration which resides on a *MAXIM II* Controller and allows the user to inspect, trend or modify the value at any of the points in the configuration while the controller is running.

MAXSim - The *MAXIM* Simulator utility is a Windows-based software program that simulates a *MAXIM II* Controller. The virtual *MAXIM II* can be powered on, configured and interrogated in the same way as a physical *MAXIM II*. Configurations can be downloaded and checked without requiring any hardware installation.

iComm is a communications server used by application software to communicate with Innotech digital controllers. It supports multiple concurrent applications communicating to multiple device networks and serves as the communications hub of any HMI-integrated device network.

MAXtract - is the data log extraction utility for a range of Innotech digital controllers. It allows extraction of all or part of the history log data residing on the *MAXIM II* into a specified data format.

InnoGraph - is data log graphing and analysis tool. While it has been designed to specifically cater for the data log graphing capabilities of the Innotech range, it has the flexibility to display data log graphing information from other sources. **InnoGraph** allows multiple graphs to be displayed in multiple windows simultaneously. Complete with a host of configurable display options, statistical analysis of data points, analogue and digital value support, active cursors, colour printing capability and comprehensive zooming and panning features, **InnoGraph** is your complete graphing package.

Supervisor is a specialised dynamic monitoring utility for the Genesis II and Maxim Series Digital Controllers. It provides all the functionality that is available from the Genesis II and Maxim Series Digital Controller display panels with greater ease-of-use and flexibility. It is aimed at those users who require some feedback or control of the Genesis II and Maxim system, but have no desire to be immersed in the technical details of a Genesis II and Maxim configurations.

Magellan is an event-driven, object oriented real-time Supervisory Control and Data Acquisition package. It provides a simple, intuitive mechanism to effortlessly design either trivial or sophisticated supervisory or control programs using a drag-and-drop approach.



GasTech Australia Pty Ltd
24 Baretta Rd
Wangara Western Australia 6065
Tel 1800 999 902
Fax 1800 999 903
<http://www.gastech.com.au>

FCC Class A Notice

This device complies with Part 15 of the FCC Rules. Operation is subject to the following two conditions:

1. This device may not cause harmful interference.
2. This device must accept any interference received, including interference that may cause undesired operation.

Note – This equipment has been tested and found to comply with the limits for a Class A digital device, pursuant to Part 15 of the FCC Rules. These limits are designed to provide reasonable protection against harmful interference when the equipment is operated in a commercial environment. This equipment generates, uses and can radiate radio frequency energy and, if not installed and used in accordance with the instruction manual, may cause harmful interference to radio communications.

Operation of this equipment in a residential area is likely to cause harmful interference in which case the user will be required to correct the interference at his own expense.

Modifications to this device, may void the authority granted to the user by the FCC to operate this equipment.

Maxim II Controller

